

MAXI

Rimadesio

Ceiling rail

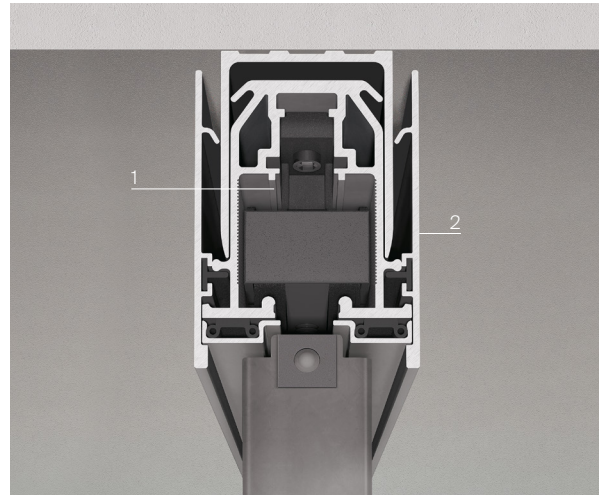

Single rail

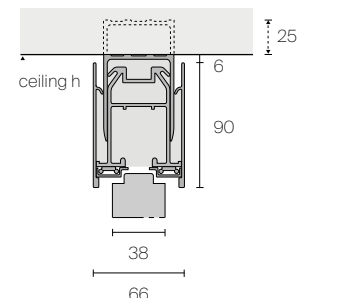

Single rail Maxi

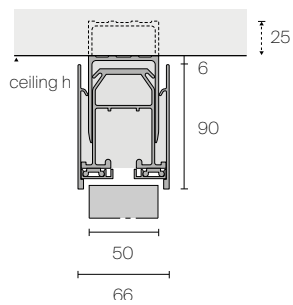

Double rail

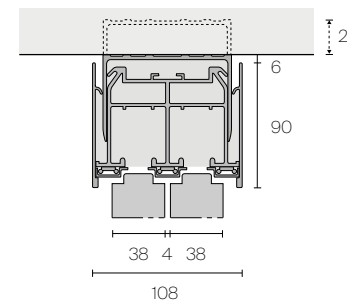

Double rail Maxi

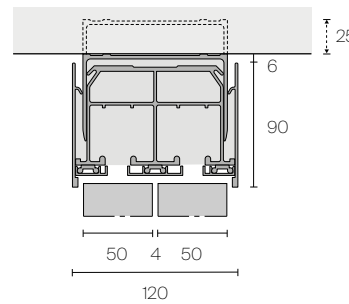

Three ways rail

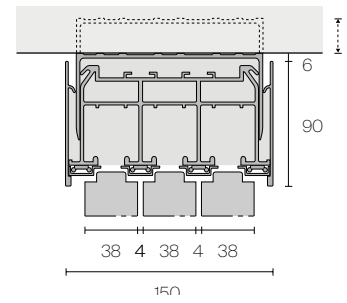

Four ways rail

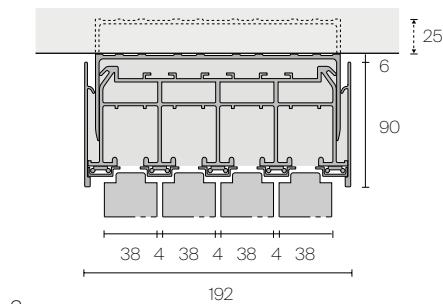

Built-in rail

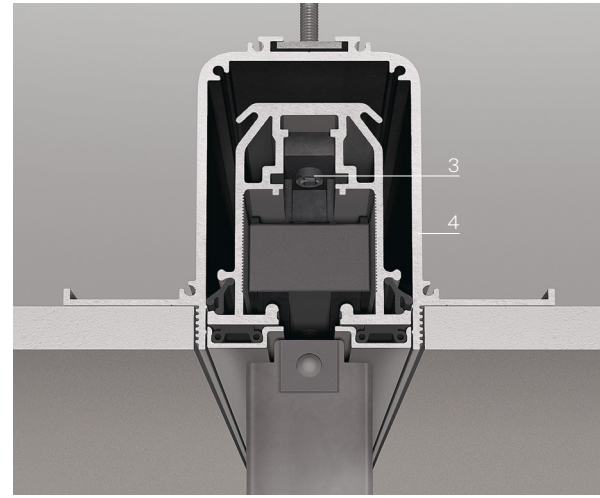

Single rail

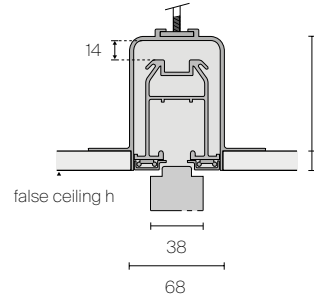

Single rail Maxi

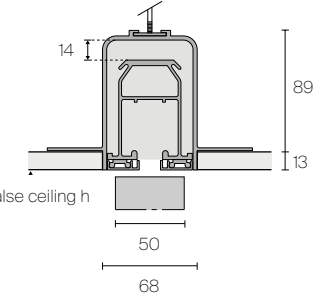

Double rail

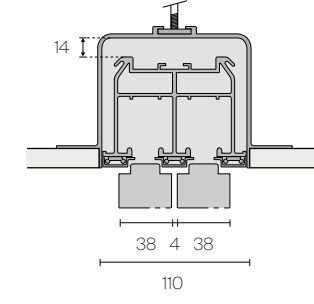

Double rail Maxi

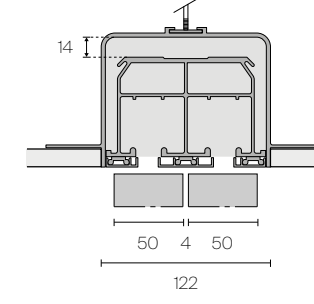

Three ways rail

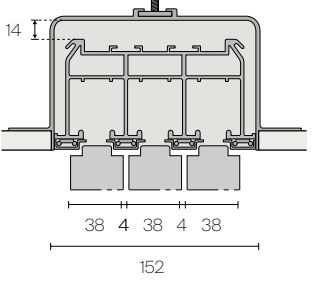

Three ways rail Maxi

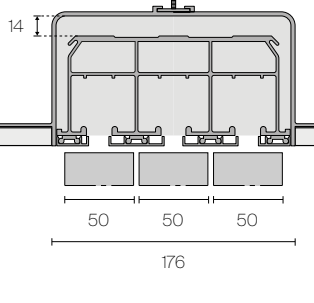

Four ways rail

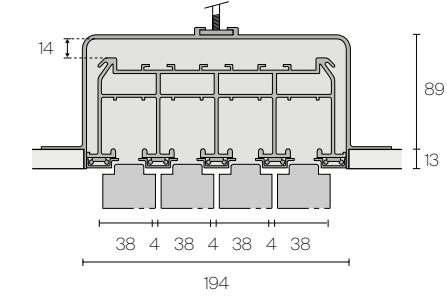

Wall rail

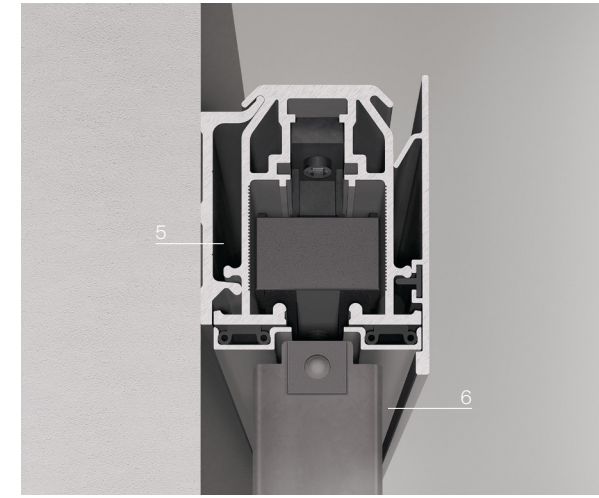

Single rail

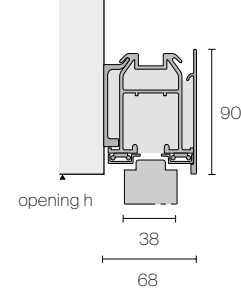

Double rail

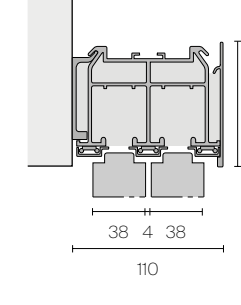

Single rail Maxi

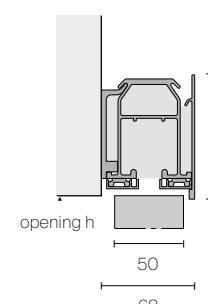

- Sliding rail with patented telescopic adjusting profile. It allows to counterbalance differences in ceiling height without the use of paddings or coverings. Exceptional dimensions in length till 6000 mm.
- Closing cover for rail in extruded aluminium. Quick assembling.
- Patented sliding profile in extruded aluminium.
- Aluminium total built-in profile. Rail adjustable for 14 mm.
- Wall fixing section in hardened aluminium alloy (EN AW-6005A). Guaranteed for loads of 100 kg per linear meter.
- Patented aluminium covering profile with quick fixing system, in the same colour of the sliding panel structure or prepared to be painted on site to match the ceiling.

- Binario di scorrimento con profilo telescopico di aggiustaggio brevettato. Consente la perfetta messa in bolla del binario di scorrimento e di compensare gli eventuali dislivelli del soffitto, senza fasce di tamponamento e spessori aggiuntivi. Dimensioni in lunghezza fino a 6000 mm.
- Veletta copri-binario in estruso di alluminio. Montaggio rapido ad incastro.
- Profilo di scorrimento brevettato in estruso d'alluminio.
- Profilo in alluminio ad incasso totale. Binario di scorrimento dotato di regolazione in altezza di 14 mm.
- Profilo di ancoraggio a parete in lega di alluminio (EN AW-6005A) temperato. Garantito per carichi di 100 kg per metro lineare.
- Profilo di copertura brevettato in alluminio ad ancoraggio rapido, in tinta alla struttura della porta scorrevole o predisposto per la verniciatura in loco in tinta al soffitto.

- Laufschiene mit neuem patentierten teleskopischen Profil. Sie erlaubt eine Ausgleichung eventueller Decken-unebenheiten ohne zusätzliche Vorarbeiten. Gesamtlänge von 6000 mm lieferbar.
- Blende aus gezogenen Aluminiumguss, schnelle Klick-Montage.
- Patentiertes Laufprofil aus Druckguss Aluminium.
- Eingebauter Aluminiumprofil. Laufschiene regulierbar in Höhe von 14 mm.
- Decke-Befestigungsprofil aus temperierter Aluminium-Legierung (EN AW-6005A). Garantierte Tragfähigkeit 100Kg pro Laufmeter.
- Patentiertes Abdeckprofil aus Aluminium mit System zur schnellen Montage. Erhältlich in der Strukturfarbe der Schiebepaneele oder grundiert, um vor Ort in der Deckenfarbe lackiert zu werden.

- Rail de coulissement avec profil télescopique d'ajustage. Il permet de compenser les éventuels défauts du plafond, sans l'utilisation d'aucun type de tamponnement. Dimensions exceptionnelles en longueur jusqu'à 6000 mm.
- Bandeau de fermeture en extrudé d'aluminium. Montage à encastrement rapide.
- Profil de coulissement breveté en extrudé d'aluminium.
- Profil en aluminium à encastrement complètement. Rail de coulissement réglable en hauteur de 14 mm.
- Profil de fixation mural en alliage d'aluminium trempé (EN AW-6005A). Garanti pour poids de 100 Kg par mt.lin.
- Profil de couverture breveté en aluminium avec système de fixation rapide, dans la même finition de la structure du panneau coulissant ou prêt pour la peinture sur place dans la teinte du plafond.

- Guía con perfil telescópico de ajuste patentado. Permite de ajustar eventuales desniveles del techo, sin bandas y espesores añadidos. Dimensiones excepcionales hasta 6000 mm.
- Tapa de cierre en extrusión de aluminio. Montaje rápido a encaje.
- Perfil corredero patentado en extrusión de aluminio.
- Perfil en aluminio totalmente embutido. Guía dotada de regulación en altura de 14 mm.
- Perfil de anclaje a pared en aleación de aluminio (EN AW-6005A) templado. Garantizado para cargas de 100 Kg por metro lineal.
- Perfil embellecedor en aluminio de sujeción rápida patentado, combinado a la estructura del panel corredero o preparado para la pintura en obra combinada al acabado del techo.

- Направляющий рельс снабжен запатентованным телескопическим регулирующим профилем. С его помощью можно идеально выровнять направляющий рельс и компенсировать любые неровности потолка, не используя дополнительные накладки и прокладки. Размеры в длину до 6000 мм.
- Накладка рельса изготовлена из экструдированного алюминия. Быстрая сборка со скрытым креплением.
- Запатентованный направляющий профиль изготовлен из экструдированного алюминия.
- Полностью скрытый алюминиевый профиль. Направляющий рельс с регулировкой высоты 14 мм.
- Профиль для крепления к стене изготовлен из закаленного алюминиевого сплава (EN AW-6005A). Выдерживает нагрузку 100 кг на погонный метр.
- Запатентованный алюминиевый накладной профиль быстрого крепления окрашен в цвет, соответствующий цвету конструкции раздвижной двери, или подготовлен к окраске на месте для соответствия цвету потолка.

- 滑轨配备专利伸缩调节型材。该专利型材可为滑轨完美找平，补偿天花板的平整之处，无需额外使用找平条和找平垫片。尺寸最长可达 6000 毫米。
- 滑轨盖板由挤出铝合金制成。联锁式快速组装。
- 获得专利的挤压铝滑动型材。
- 墙面的锚式固定型材材质为钢化铝合金 (EN AW-6005A)。保证承重为每延米 100 公斤。
- 专利型铝质外罩型材，可快速固定，可与推拉门结构互相协调；或在现场进行涂装，与天花板互相协调。

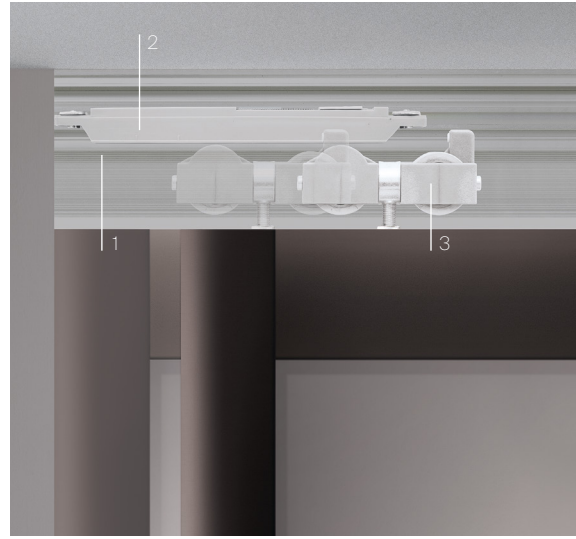

1. Sliding rail with patented adjustment telescopic section. It allows for the perfect levelling of the sliding rail and it compensates. Height adjustment of 25 mm for the ceiling rail version.
2. Soft motion brake, equipped with a recall spring and an air piston which are inserted into a nylon fibre injectionmoulded support.
3. Sliding carriage. Nylon body tipping on two axes, designed to allow any imperfections in the wall and ceiling, always guaranteeing perfect sliding. Nylon and fibreglass wheels. Max load-bearing capacity per carriage 100 kg.

1. Binario di scorrimento con profilo telescopico di aggiustaggio brevettato. Consente la perfetta messa in bolla del binario di scorrimento. Regolazione in altezza di 25 mm per la versione a soffitto.
2. Freno soft motion, dotato di molle di richiamo e pistoncino ad aria, inseriti in un supporto in nylon fibra stampato ad iniezione.
3. Carrello di scorrimento. Corpo in nylon basculante su due assi, progettato per seguire le eventuali imperfezioni della parete e del soffitto garantendo uno scorrimento sempre perfetto. Ruote in nylon e fibra di vetro. Portata max 100 kg per carrello.

1. Gleitschiene mit patentiertem Teleskopprofil zur Justierung Ermöglicht eine perfekte waagerechte Ausrichtung der Gleitschiene. Höhenregulierung um 25 mm für Deckenschiene.

2. Eingebauter Soft-Motion Bremse, mit der Rückkehr Federn und Kolben-Öl ausgestattet, die in der spritzgegossenen Unterstüzung von Nylon-Faser, eingebaut sind.
3. Laufwagen Doppelgehäuse aus Nylon, zweiachsig schwingend, geplant, um eventuelle Unebenheiten an Wand und Decke auszugleichen und ein perfektes Gleiten in jeder Situation zu garantieren. Rollen aus Nylon und Glasfaser. Höchstlast pro Laufwagen 100 kg.

1. Rail de coulissement avec profilé télescopique d'ajustage breveté. Il permet de mettre parfaitement à niveau le rail de coulissement. Réglage en hauteur de 25 mm pour la version de plafond.
2. Frein soft motion avec ressorts de retour et petit piston à huile, insérés dans un support en fibre de nylon moulé par injection.
3. Chariot de coulissement. Corps en nylon, basculant sur deux axes, étudié pour suivre les éventuelles imperfections du mur et du plafond en garantissant un coulissement toujours parfait. Roulettes en nylon et fibre de verre. Charge maximale de 100 kg par chariot.

1. Guía de deslizamiento con perfil telescópico de ajuste patentado. Permite un perfecto alineamiento de la guía. Regulación de la altura de 25 mm para la versión de techo.
2. Freno soft motion, equipado con resortes de retorno y de pistón al aceite, colocados en un soporte en fibra de nylon, moldeado por inyección.
3. Carro de deslizamiento. Cuerpo de nylon basculante sobre dos ejes, diseñado para seguir las eventuales imperfecciones de la pared y del techo garantizando un deslizamiento siempre perfecto. Ruedas de nylon y fibra de vidrio. Carga útil máx. 100 kg por carro.

1. Направляющий рельс снабжен запатентованным телескопическим регулирующим профилем. Он обеспечивает идеальное выравнивание направляющего рельса. Регулировка высоты на 25 мм для потолочного исполнения.
2. Тормоз плавного хода оснащен возвратными пружинами и пневматическим поршнем, которые установлены в корпус из нейлонового волокна, изготовленный литьем под давлением.
3. Направляющая каретка. Нейлоновый корпус, качающийся на двух осях, разработан с учетом любых дефектов стен и потолка, всегда обеспечивая идеальное скольжение. Колеса изготовлены из нейлона и стекловолокна. Максимальная грузоподъемность каждой каретки 100 кг.

1. 滑轨配备专利型伸缩调节型材。为滑轨完美找平。天花板版本的高度调节量为 25 毫米。
2. 阻尼器，以尼龙纤维注塑成型制成的气缸和内部的复位弹簧和空气活塞组成。
3. 滑轮。双轴的摇摆轴承车体搭配尼龙滑轮，为解决墙面和天花板不平整的问题研发而成，确保始终完美的推拉体验。滑轮材质为尼龙纤维和玻璃纤维。单只滑车最大承重为 100 公斤。

RAIL IN THE SAME FINISHING OF THE PANEL STRUCTURE OR READY TO BE PAINTED ON SITE

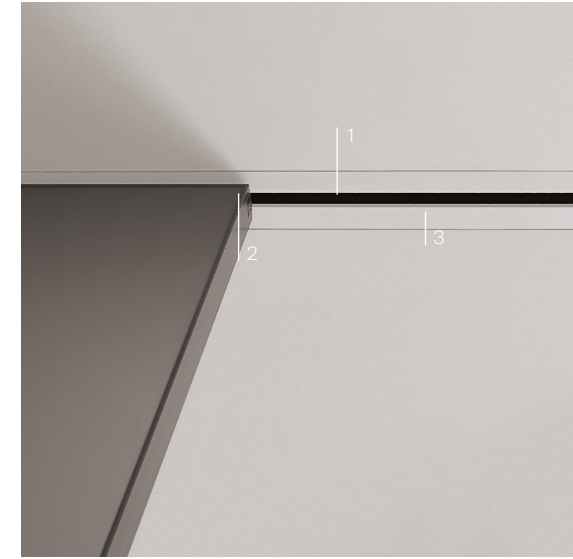

1. Patented sliding profile with internal micro finning, designed to reduce and deaden the noise of the panel when it slides.
2. Adjustment in height of the panel thanks to the lateral cardan joint. The adjustment is possible also with the panel already mounted in order to simplify to the maximum the assembly operations.
3. Patented covering profiles in aluminium prepared to be painted to match the ceiling.
4. Patented covering profiles in extruded aluminium with quick fixing system, in the same finishing of the sliding panels structure.

1. Profilo di scorrimento brevettato con microaletture interne, studiate per ridurre e attutire il rumore durante lo scorrimento del pannello.
2. Regolazione in altezza del pannello mediante giunto cardanico laterale: la regolazione è effettuabile anche con il pannello già montato per semplificare al massimo le operazioni di montaggio.
3. Profili di copertura in alluminio predisposti per la verniciatura in loco in tinta al soffitto.
4. Profili di copertura brevettati in estruso di alluminio ad aggancio rapido, in tinta alla struttura delle porte scorrevoli.

1. Patentiertes Laufprofil mit Mikroinnenrippen, die die Gleitgeräusche der Türplatte verringern.

2. Höhenregulierung der Türplatte mittels eines Kardangelenkes. Zur weiteren Vereinfachung der Montage ist die Regulierung auch möglich, wenn die Platte bereits installiert ist.
3. Die vor Ort Lackierung der Aluminiumabdeckungen sind in derselben Farbe der Decke erhältlich.
4. Patentierte Schnellkupplung Aluminiumabdeckungen sind in derselben Farbe der Türplatte erhältlich.

1. Profil de coulissement breveté avec des petites ailettes internes, conçu pour réduire et amortir le bruit lors du coulissement du panneau.
2. Réglage en hauteur du panneau par joint de cardan latéral. Le réglage est également réalisable sur le panneau déjà monté afin de simplifier au maximum les opérations de montage.
3. Profils de finition en aluminium préparé pour la peinture sur place dans la même couleur du plafond.
4. Profils de finition en extrusion d'aluminium avec fixation rapide, dans la même couleur de la structure des panneaux coulissants.

1. Guía corredera patentada con micro aletas internas, diseñadas para reducir y amortiguar el ruido durante el deslizamiento del panel.
2. Regulación en altura del panel por medio de cardán lateral. El ajuste también es posible con el panel ya montado para simplificar las operaciones de montaje.
3. Perfiles embellecedores en aluminio preparados para ser pintados en obra en el mismo color del techo.
4. Perfiles embellecedores patentados en extrusión de aluminio con enganche rápido, del mismo color que la estructura del panel.

1. Запатентованный направляющий профиль выполнен с внутренними микроребрами, предназначенными для снижения и гашения шума при перемещении панели.
2. Регулировка панели по высоте производится Сбоку с помощью шарнирного соединения. Можно производит регулировку уже собранной панели, чтобы максимально упростить операции монтажа.
3. Накладные профили из алюминия могут быть окрашены на месте в соответствии с цветом потолка.
4. Запатентованные накладные профили быстрого крепления из экструдированного алюминия окрашены в цвет, соответствующий цвету конструкции раздвижных дверей.

5. 专利型滑动型材的内部具有微型翅片，专为减少门板滑动时所产生的噪音研发而成。
6. 通过侧面的万向接头来调整门板的高度：为尽可能简化组装工作，亦可在组装好门板后再进行调节。
7. 铝质盖板型材可在现场涂装，以与天花板互相协调。
8. 专利型挤出铝合金的盖板型材配备快速耦合装置，与推拉门结构互相协调。

Door panel

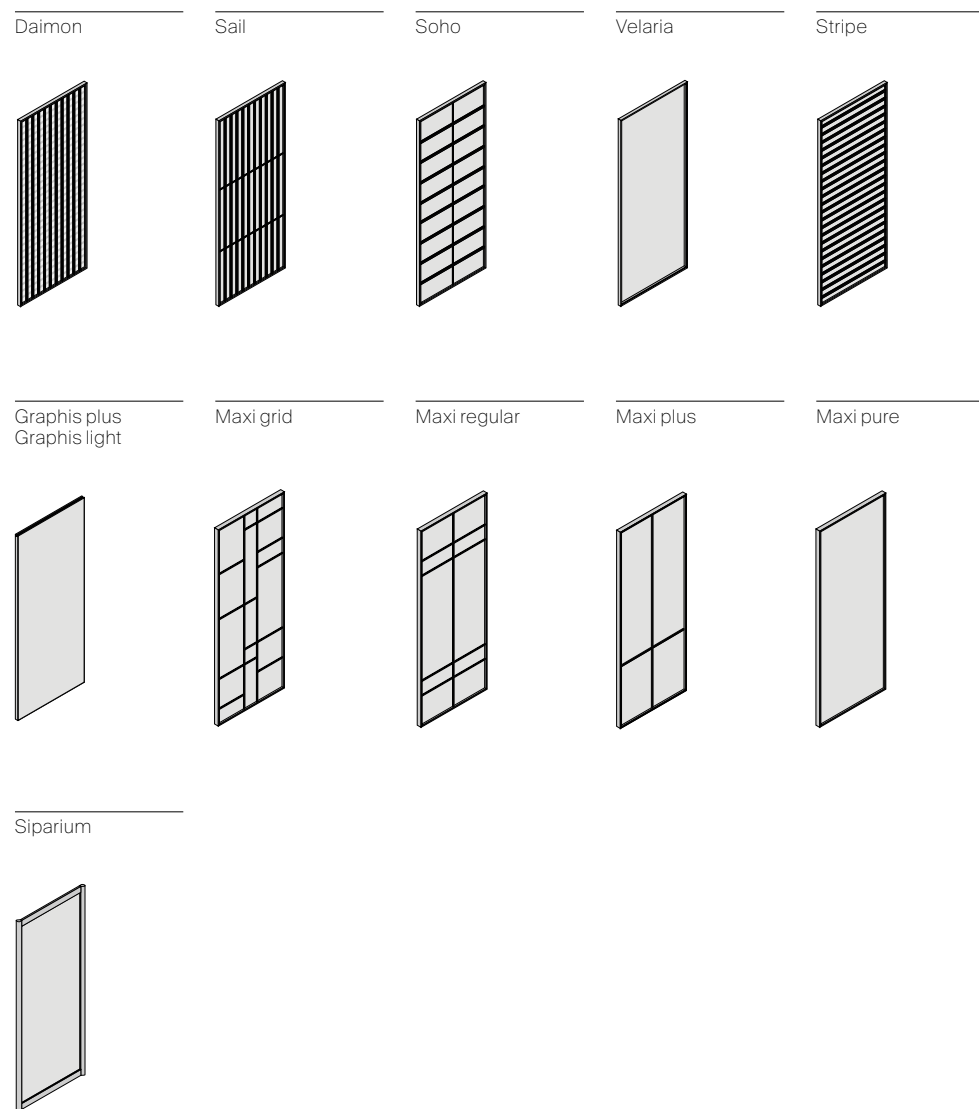
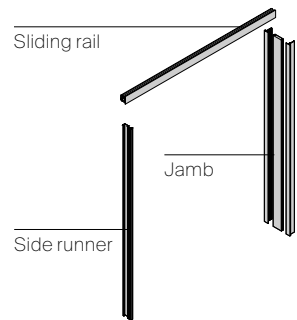

TECHNICAL DESCRIPTION

EN All the Rimadesio sliding doors have been engineered to guarantee maximum design simplicity and to be installed on the exclusive wall, ceiling and built-in sliding system. A complete sliding door consists of a sliding rail, a door panel and an optional finishing jamb or side jamb. Folding and hinged doors are available for Siparium panels only. The system uses a sliding rail and carriages that differ from the linear sliding model.

IT Tutte le porte scorrevoli Rimadesio sono state ingegnerizzate per garantire la massima semplicità di progettazione e per essere installate sull'esclusivo sistema di scorrimento a parete, soffitto e incasso. Una porta scorrevole completa è composta da un binario di scorrimento, un pannello porta e uno stipite o montante laterale di finitura opzionale. L'apertura a libro e battente è disponibile unicamente per i pannelli Siparium. Il sistema utilizza un binario di scorrimento e carrelli differenti dal modello a scorrimento lineare.

DE Alle Rimadesio-Schiebetüren sind so konstruiert, dass sie einfach zu gestalten sind und in das einzigartige Wand-, Decken- und Einbau-Schiebesystem eingebaut werden können. Eine komplette Schiebetür besteht aus einer Laufschiene, einer Türplatte und einem optionalen Abschlusspfosten oder Seitenpfosten. Die Fall- und Schwenköffnung ist nur für Siparium-Platten verfügbar. Das System verwendet eine andere Gleitschiene und andere Drehgestelle als das lineare Gleitmodell.

FR Toutes les portes coulissantes Rimadesio ont été conçues pour garantir une simplicité de conception maximale et pour être installées sur le système coulissant exclusif mural, plafond et encastré. Une porte coulissante complète se compose d'un rail coulissant, d'un panneau de porte et d'un montant ou d'un jambage latéral de finition en option. Seuls les panneaux Siparium sont disponibles avec une ouverture en accordéon et battante. Ce système utilise un rail coulissant et des chariots différents du modèle coulissant linéaire.

ES Todas las puertas correderas Rimadesio están diseñadas para garantizar la máxima sencillez de diseño y para instalarse en el exclusivo sistema corredero de pared, techo y empotrado. Una puerta corredera completa, que consta de una guía corredera, un panel de puerta y una jamba o montante lateral de acabado opcional. La apertura plegable y batiente solo está disponible para paneles Siparium. El sistema utiliza una guía deslizante y carros diferentes que el modelo corredero lineal.

RU Все раздвижные двери Rimadesio разработаны для максимального облегчения процесса проектирования и встраивания в уникальную раздвижную систему стен и потолок. Раздвижная дверь в сборе состоит из направляющего рельса, дверной панели и дополнительного откоса или бокового бруса дверной коробки. Открывание распашное или книжкой выполняется только для панелей Siparium. В этой системе используются направляющие рельсы и каретки с нелинейной моделью перемещения.

汉语 Rimadesio 所有款式的推拉门皆经过精心研发, 以便安装在独特的壁面式、天花板式和嵌入式滑动系统上, 确保规划上极大的简易性。一组完整的推拉门由滑轨、门板以及门套或侧柱组成(可选表面处理)。铰链式自由门仅适用 Siparium 系列的门板。这套系统采用不同于线性滑动型号的滑轨和滑轮。

Ceiling rail

Velaria, Soho, Stripe, Sail, Daimon
H panel = minimum H ceiling - 97 mm

Maxi, Graphis plus, Graphis light, Siparium
H panel = minimum H ceiling - 104 mm

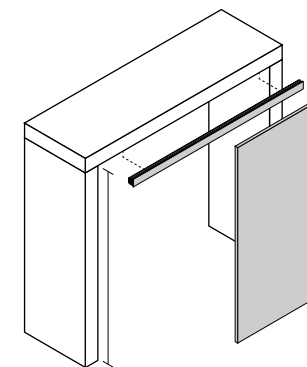

Wall rail

Velaria, Soho, Stripe, Sail, Daimon
H panel = maximum opening H + 4 mm

Maxi, Graphis plus, Graphis light, Siparium
H panel = maximum opening H - 3 mm

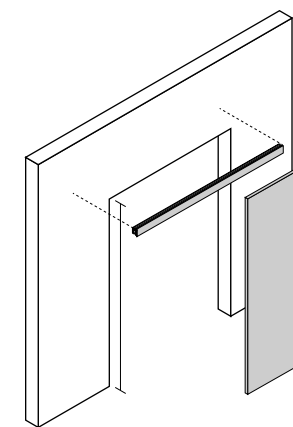

Built-in rail

Velaria, Soho, Stripe, Sail, Daimon
H panel = minimum H false ceiling - 8 mm

Maxi, Graphis plus, Graphis light, Siparium
H panel = minimum H false ceiling - 15 mm

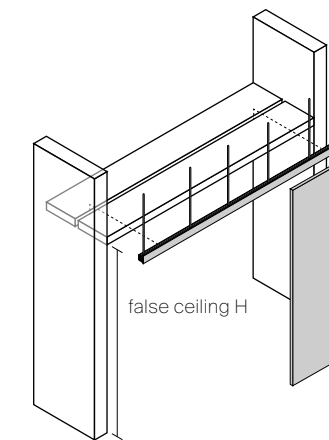

PANELS WIDTH CALCULATION

Single rail out of the opening

Lateral opening to the right, with side runner

Velaria, Stripe, Sail, Soho, Daimon
 A = 13 mm
 B = 12 mm
 L = opening W - 1 mm

Graphis light
 A = 13 mm
 B = 20 mm
 L = opening W + 7 mm

Graphis plus
 A = 13 mm
 B = 15 mm
 L = opening W + 2 mm

Siparium
 A = 15 mm
 B = 25 mm
 L = opening W + 10 mm

Maxi
 not available

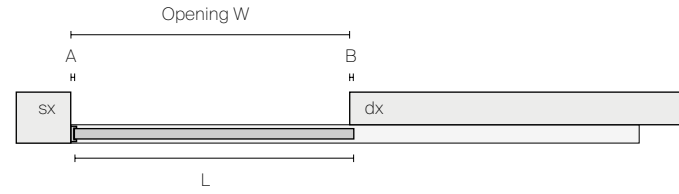

Lateral opening to the right, without side runner

Velaria, Stripe, Sail, Soho, Daimon
 A = 12 mm
 L = opening W + 24 mm

Graphis light
 A = 20 mm
 L = opening W + 40 mm

Graphis plus
 A = 15 mm
 L = opening W + 30 mm

Siparium
 A = 25 mm
 L = opening W + 50 mm

Maxi
 A = 15 mm
 L = opening W + 30 mm

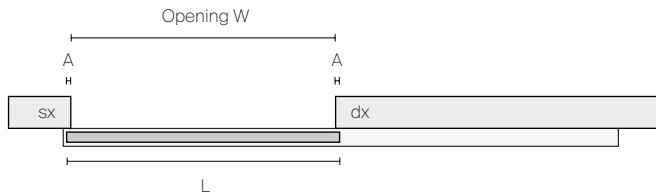

Central opening, without side runners

Velaria, Stripe, Sail, Soho, Daimon
 A = 2 mm
 L = (opening W + 22 mm) ÷ 2

Graphis light
 A = 20 mm
 L = (opening W + 40 mm) ÷ 2

Graphis plus
 A = 15 mm
 B = 0 mm
 L = (opening W + 30 mm) ÷ 2

Siparium
 A = 25 mm
 B = 0 mm
 L = (opening W + 50 mm) ÷ 2

Maxi
 A = 15 mm
 B = 2 mm
 L = (opening W + 28 mm) ÷ 2

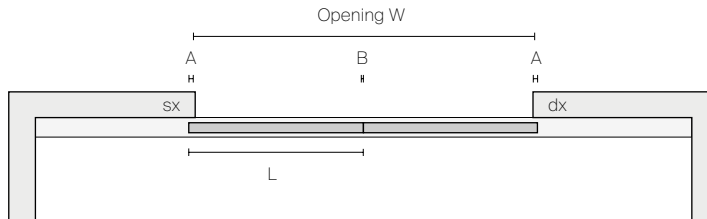

Double rail in the opening

Lateral opening, with side runners

Velaria, Stripe, Sail, Soho, Daimon
 A = 13 mm
 B = 12 mm
 L = (opening W - 14 mm) ÷ 2

Graphis light
 A = 13 mm
 B = 13 mm
 L = (opening W - 13 mm) ÷ 2

Graphis plus
 A = 13 mm
 B = 30 mm
 L = (opening W + 4 mm) ÷ 2

Siparium
 A = 15 mm
 B = 50 mm
 L = (opening W + 20 mm) ÷ 2

Maxi
 not available

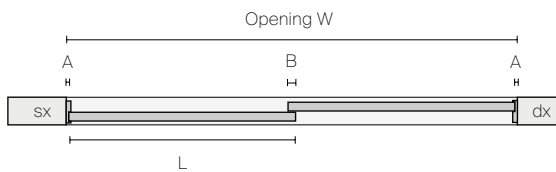

Double rail in the opening

Lateral opening, without side runners

Velaria, Stripe, Sail, Soho, Daimon
 A = 1 mm
 B = 12 mm
 L = (opening W + 10 mm) ÷ 2

Graphis light
 A = 0 mm
 B = 13 mm
 L = (opening W + 13 mm) ÷ 2

Graphis plus
 A = 0 mm
 B = 30 mm
 L = (opening W + 30 mm) ÷ 2

Siparium
 A = 0 mm
 B = 50 mm
 L = (opening W + 50 mm) ÷ 2

Maxi
 A = 1 mm
 B = 15 mm
 L = (opening W + 13 mm) ÷ 2

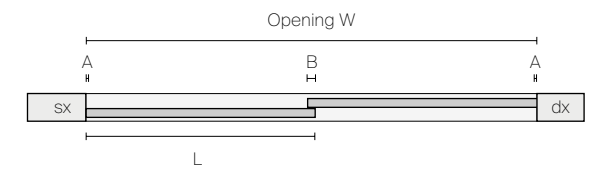

Lateral opening, with side runners

Velaria, Stripe, Sail, Soho, Daimon
 A = 13 mm
 B = 12 mm
 L = (opening W - 2 mm) ÷ 3

Graphis light
 A = 13 mm
 B = 13 mm
 L = opening W ÷ 3

Graphis plus
 A = 13 mm
 B = 30 mm
 L = (opening W + 34 mm) ÷ 3

Siparium
 A = 15 mm
 B = 50 mm
 L = (opening W + 70 mm) ÷ 3

Maxi
 not available



Central opening, without side runners

Velaria, Stripe, Sail, Soho, Daimon
 A = 12 mm
 B = 1 mm
 C = 2 mm
 L = (opening W + 20 mm) ÷ 4

Graphis light
 A = 13 mm
 B = 0 mm
 C = 0 mm
 L = (opening W + 26 mm) ÷ 4

Graphis plus
 A = 30 mm
 B = 0 mm
 C = 0 mm
 L = (opening W + 60 mm) ÷ 4

Siparium
 A = 50 mm
 B = 0 mm
 C = 0 mm
 L = (opening W + 100 mm) ÷ 4

Maxi
 A = 15 mm
 B = 1 mm
 C = 2 mm
 L = (opening W + 26 mm) ÷ 4

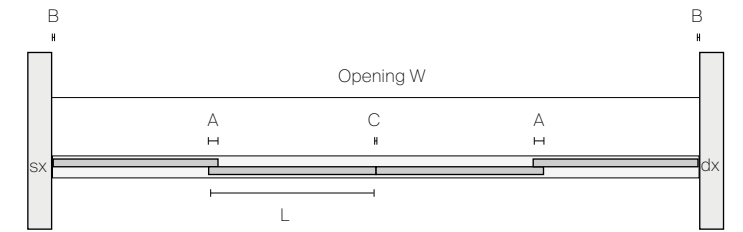

Double rail out the opening

Lateral opening to the left, without side runner

Velaria, Stripe, Sail, Soho, Daimon
 A = 12 mm
 B = 12 mm
 C = 1 mm
 L = (opening W + 23 mm) ÷ 2

Graphis light
 not available

Graphis plus
 A = 15 mm
 B = 30 mm
 C = 0 mm
 L = (opening W + 45 mm) ÷ 2

Siparium
 A = 25 mm
 B = 50 mm
 C = 0 mm
 L = (opening W + 75 mm) ÷ 2

Maxi
 A = 15 mm
 B = 15 mm
 C = 1 mm
 L = (opening W + 29 mm) ÷ 2

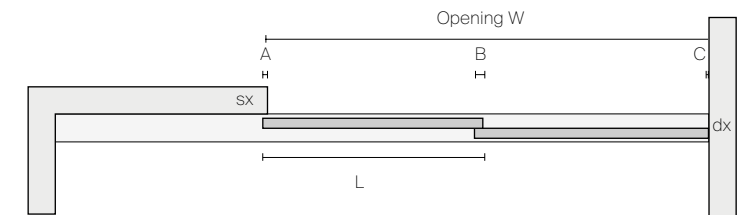

PANELS WIDTH CALCULATION

Double rail out of the opening

Central opening, without side runners

Velaria, Stripe, Sail, Soho, Daimon
 A = 12 mm
 B = 12 mm
 C = 2 mm
 L = (opening W + 46 mm) ÷ 4

Graphis plus
 A = 30 mm
 B = 15 mm
 C = 0 mm
 L = (opening W + 90 mm) ÷ 4

Graphis light
 not available

Siparium
 A = 50 mm
 B = 25 mm
 C = 0 mm
 L = (opening W + 150 mm) ÷ 4

Maxi
 A = 15 mm
 B = 15 mm
 C = 2 mm
 L = (opening W + 58 mm) ÷ 4

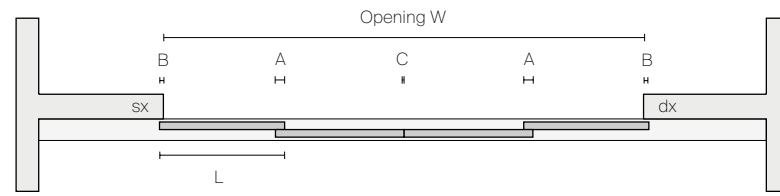

3 ways rail in the opening

Lateral opening, with 3 ways side runners

Velaria, Stripe, Sail, Soho, Daimon
 A = 12 mm
 B = 13 mm
 L = (opening W - 2 mm) ÷ 3

Graphis plus
 A = 30 mm
 B = 13 mm
 L = (opening W + 34 mm) ÷ 3

Graphis light
 not available

Siparium
 A = 50 mm
 B = 15 mm
 L = (opening W + 70 mm) ÷ 3

Maxi
 not available

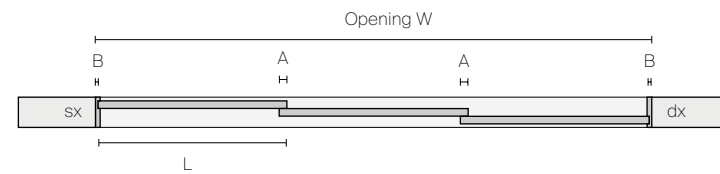

Central opening, without side runners

Velaria, Stripe, Sail, Soho, Daimon
 A = 12 mm
 B = 1 mm
 C = 2 mm
 L = (opening W + 44 mm) ÷ 6

Graphis plus
 A = 30 mm
 B = 0 mm
 C = 0 mm
 L = (opening W + 120 mm) ÷ 6

Graphis light
 not available

Siparium
 A = 50 mm
 B = 0 mm
 C = 0 mm
 L = (opening W + 200 mm) ÷ 6

Maxi
 not available

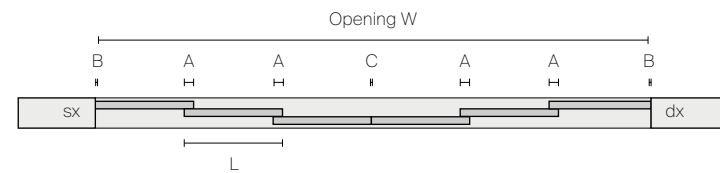

4 ways rail in the opening

Lateral opening, without side runners

Velaria, Stripe, Sail, Soho, Daimon
 A = 12 mm
 B = 1 mm
 L = (opening W + 34 mm) ÷ 4

Graphis plus
 A = 30 mm
 L = (opening W + 90 mm) ÷ 4

Graphis light
 not available

Siparium
 A = 50 mm
 L = (opening W + 150 mm) ÷ 4

Maxi
 not available

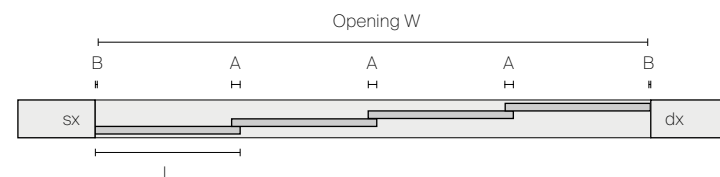

PANELS OVERLAPPING

Single rail out of the opening

Lateral opening to the right, without side runner

Velaria, Stripe, Sail, Soho, Daimon
 A = 12 mm
 B = 1 mm
 C = 32 mm
 C1 = handle 2093C = 77 mm

Graphis plus
 A = 15 mm
 B = 0 mm
 C = 15 mm
 C1 = handle 2163C, 9316 = 91 mm

Graphis light
 A = 20 mm
 B = 0 mm
 C = 39 mm

Siparium
 A = C = 25 mm
 B = 0 mm

Maxi
 A = 15 mm
 B = 1 mm
 C = 38 mm

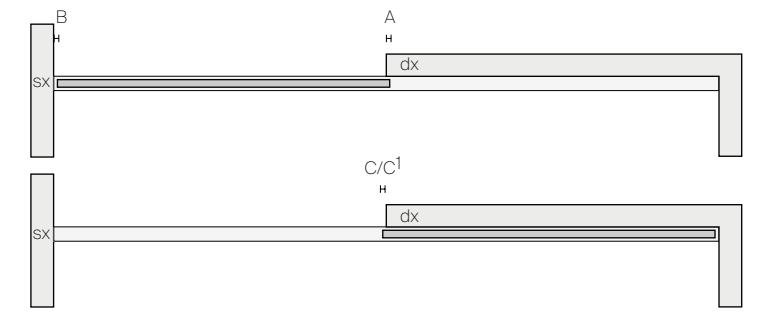

Double rail out of the opening

Lateral opening to the left, without side runner

Velaria, Stripe, Sail, Soho, Daimon
 A = 12 mm
 B = 12 mm
 C = 1 mm
 D = E = 32 mm
 E1 = handle 2093C = 77 mm

Graphis plus
 A = 30 mm
 B = 15 mm
 C = E = 0 mm
 D = 15 mm
 E1 = handle 2163C, 9316 = 76 mm

Graphis light
 not available

Siparium
 A = 50 mm
 B = D = 25 mm
 C = 0 mm
 E = 15 mm
 E1 = handle 773,551 = 78 mm

Maxi
 A = 15 mm
 B = 15 mm
 C = 1 mm
 D = 38 mm
 E = 38 mm

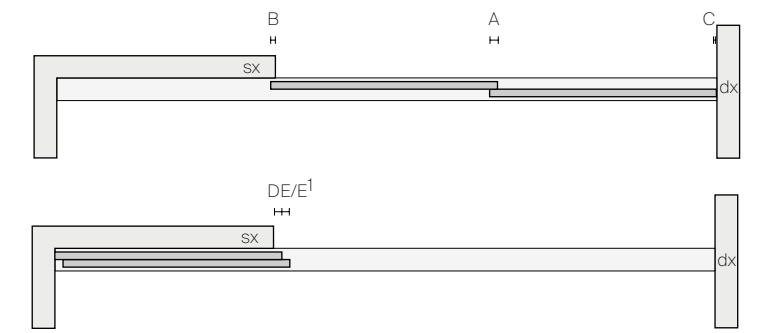

Double rail in the opening

Central opening, without side runners

Velaria, Stripe, Sail, Soho, Daimon
 A = 12 mm
 B = 1 mm
 C = 2 mm
 D = 32 mm
 D1 = handle 2093C = 77 mm

Graphis plus
 A = 30 mm
 B = C = D = 0 mm
 D1 = handle 2163C, 9316 = 76 mm

Graphis light
 A = 13 mm
 B = C = 0 mm
 D = 46 mm

Siparium
 A = 50 mm
 B = C = 0 mm
 D = 15 mm
 D1 = handle 773,551 = 78 mm

Maxi
 A = 15 mm
 B = 1 mm
 C = 2 mm
 D = 38 mm



3 ways rail in the opening

Lateral opening, with 3 ways side runners

Velaria, Stripe, Sail, Soho, Daimon
 A = 12 mm
 B = 13 mm
 C = 22 mm
 D = 48 mm
 E = 32 mm
 E1 = handle 2093C = 77 mm

Graphis plus
 A = 30 mm
 B = 13 mm
 C = 22 mm
 D = 9 mm
 E = 0 mm
 E1 = handle 2163C, 9316 = 76 mm

Graphis light
 not available

Siparium
 A = 50 mm
 B = D = E = 15 mm
 C = 30 mm
 E1 = handle 773,551 = 78 mm

Maxi
 not available

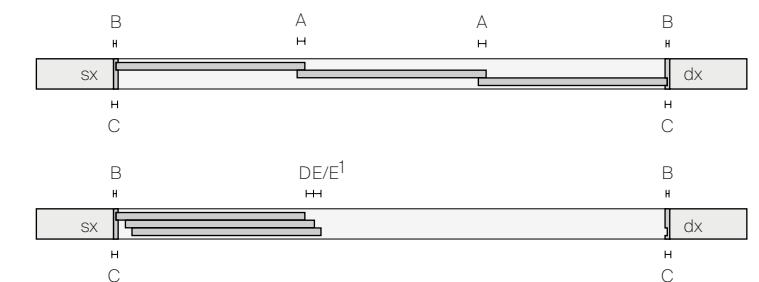

Single rail in the opening

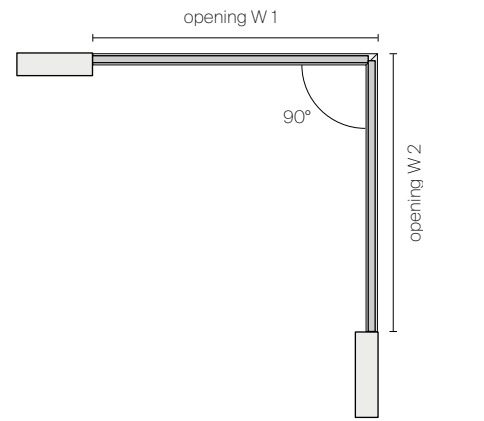

Single rail out of the opening

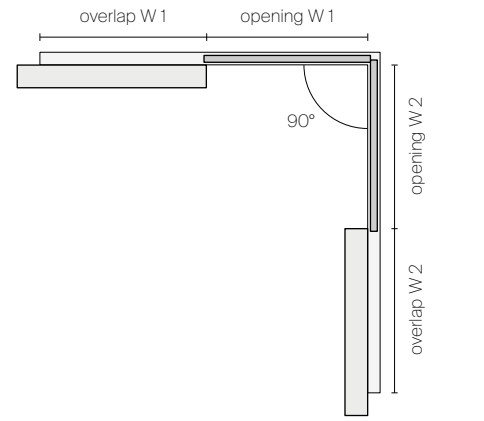

Single and double rail in the opening

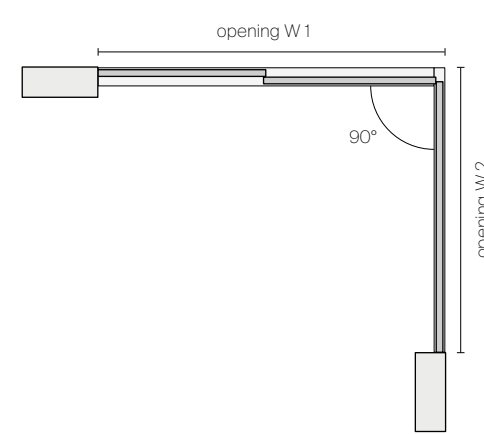

Single and double rail out of the opening

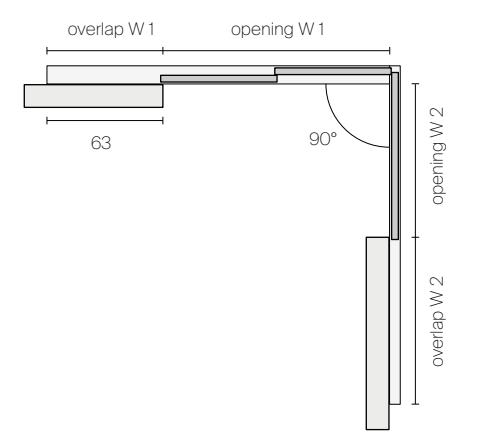

Double rail in the opening

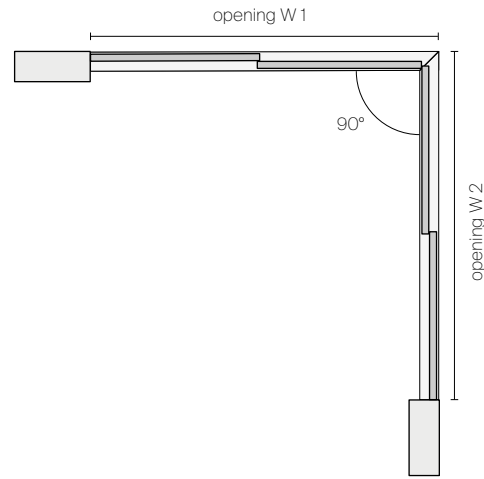

Double rail out of the opening

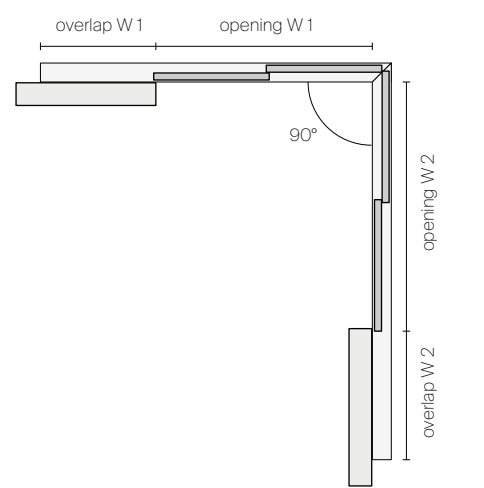

Double and 3 ways rail in the opening

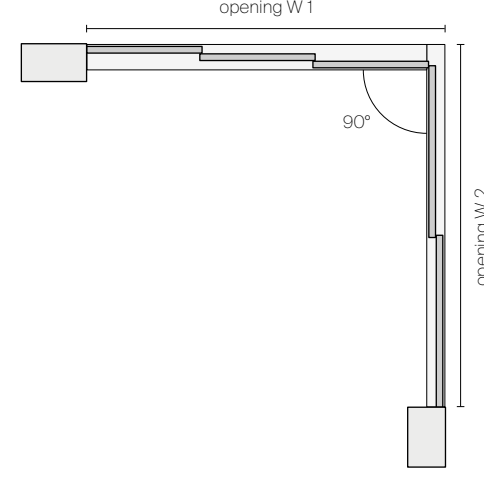

Double and 3 ways rail out of the opening

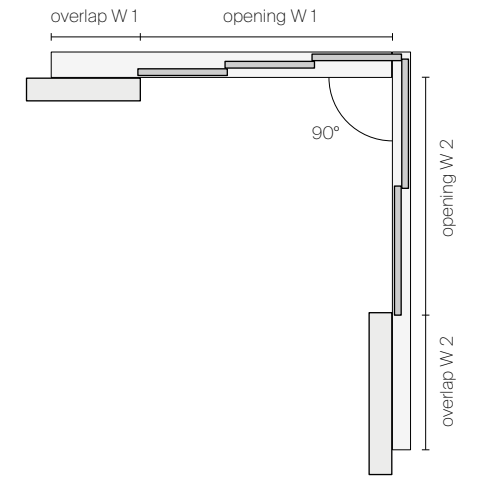

3 ways rail in the opening

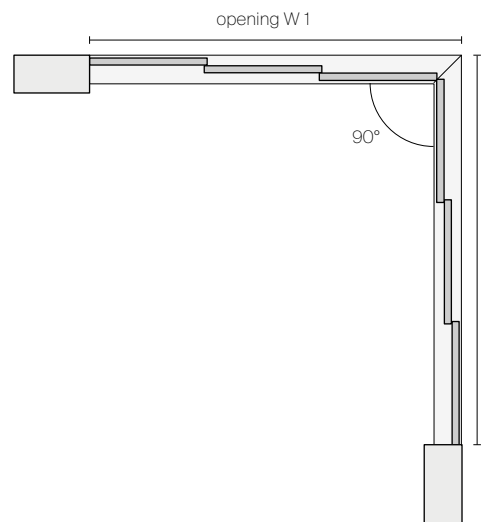

3 ways rail out of the opening

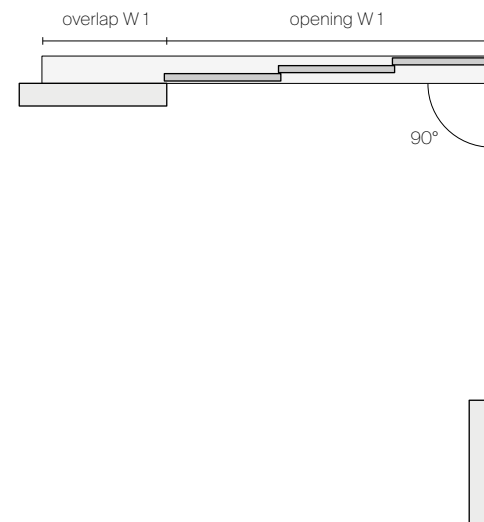

Double and 4 ways rail in the opening

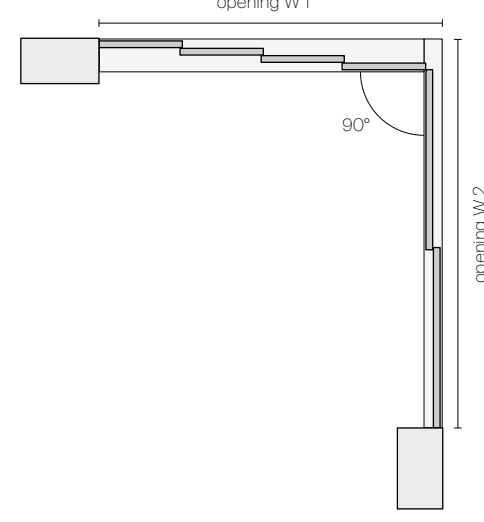

Double and 4 ways rail out of the opening

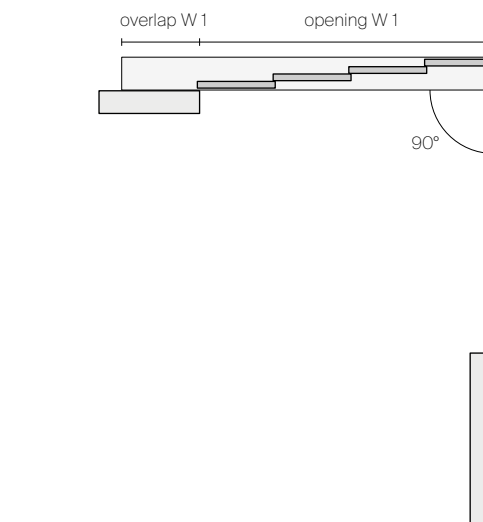

Single pocket door with fanlight

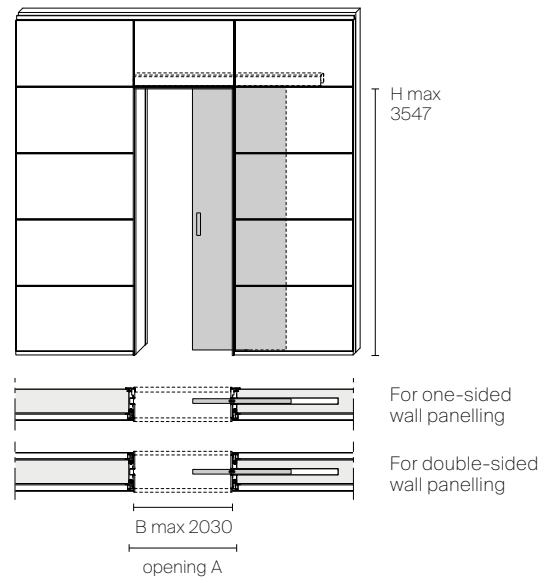

Double pocket door with fanlight

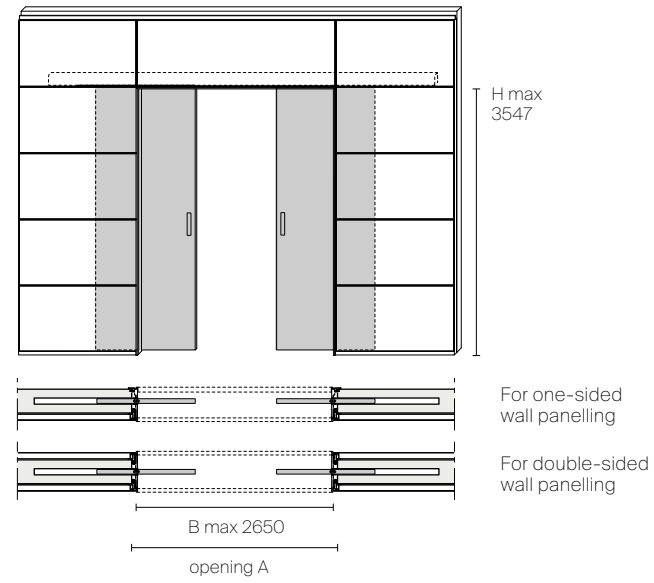

Full-height single pocket door

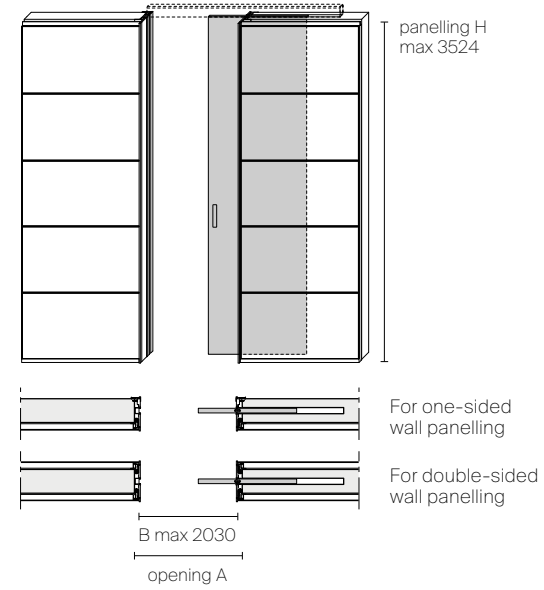

Full-height double pocket door

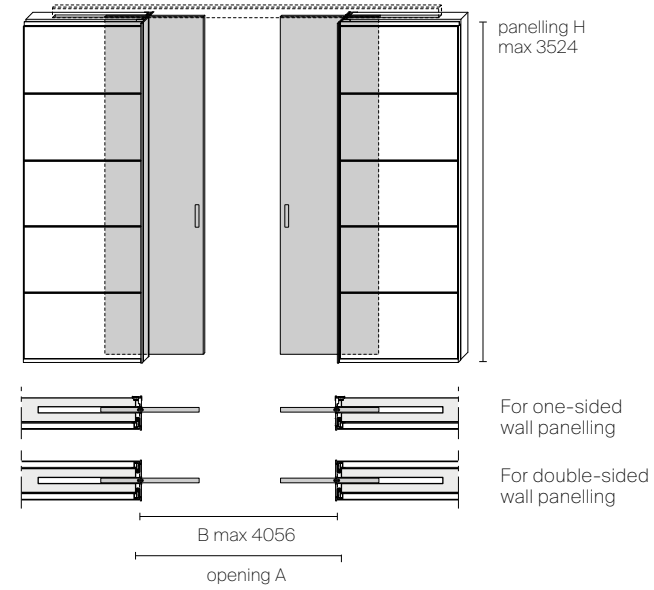

Full-height single pocket door against Modulo panel

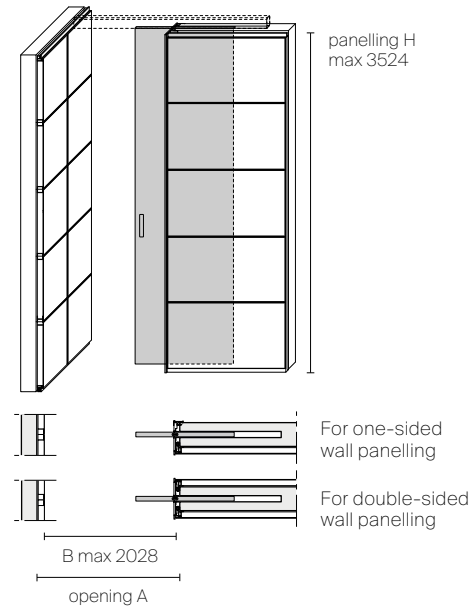

Full-height single pocket door against wall

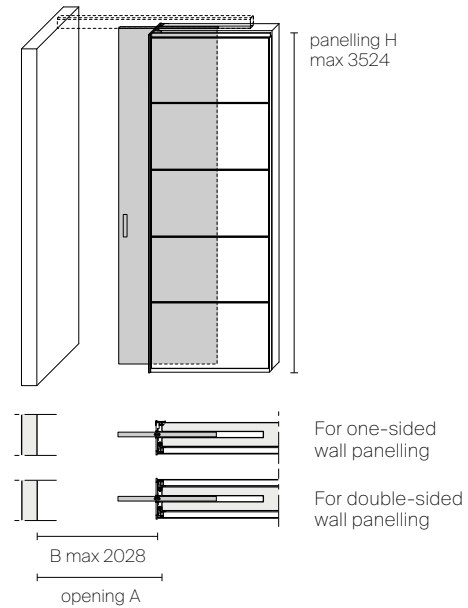

Aesthetical typologies doors panel

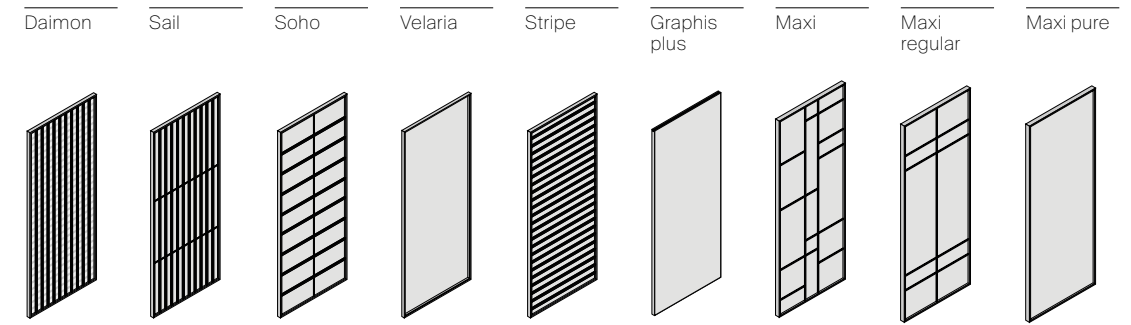

Single rails for linear sliding panels

Single built-in rail

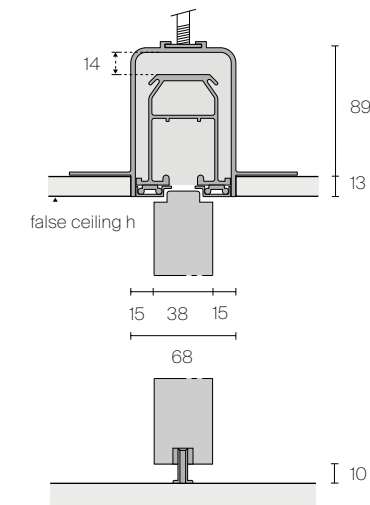

Single built-in rail Maxi

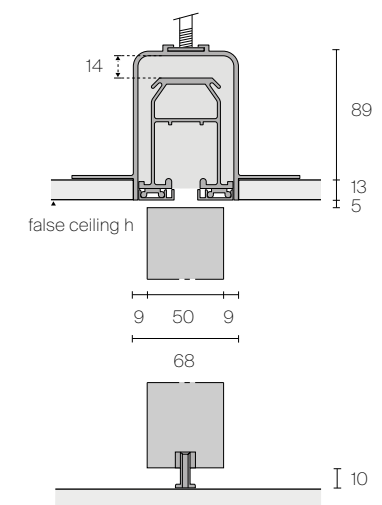



THE MAXI SLIDING SYSTEM IS CHARACTERIZED BY AN ALUMINIUM GRID THAT EMPHASIZES THE GLASS SURFACES, GIVING MAXIMUM STRENGTH AND STABILITY TO THE STRUCTURE. THE IRREGULAR GRID PATTERN ENHANCES THE QUALITY OF THE GLASS AND ITS VEILED TRANSPARENCY. THE WIDE DESIGN FLEXIBILITY ALLOWS TO CREATE CUSTOMIZED COMPOSITIONS, IDEAL FOR DOMESTIC, PROFESSIONAL, HOSPITALITY AND RETAIL CONTEXTS.

IT Il sistema scorrevole Maxi è contraddistinto da un reticolo in alluminio che scandisce le superfici in vetro, conferendo massima resistenza e stabilità alla struttura. La partitura irregolare esalta le qualità del vetro e ne valorizza le velate trasparenze. L'ampia flessibilità progettuale consente di realizzare composizioni personalizzate, ideali per contesti domestici, professionali, hospitality e retail.

DE Das Maxi-Schiebesystem zeichnet sich durch ein Aluminiumgitter aus, das die Glasoberflächen markiert und der Struktur maximale Beständigkeit und Stabilität verleiht. Die unregelmäßige Punktzahl verbessert die Eigenschaften des Glases und die verschleierte Transparenz. Die große Designflexibilität ermöglicht es, maßgeschneiderte Kompositionen zu erstellen, die sich ideal für den privaten, beruflichen, Gastgewerbe- und Einzelhandelskontext eignen.

FR Le système coulissant Maxi est caractérisé par un grille en aluminium qui parcourt les surfaces en verre, en donnant à la structure une résistance et une stabilité maximum. La répartition irrégulière exalte les qualités du verre et met en valeur les transparences voilées. La grande flexibilité de conception permet de réaliser des compositions personnalisées, idéales dans des cadres d'habitation, professionnels, en hôtellerie et retail.

ES El sistema corredero Maxi se caracteriza por una rejilla de aluminio que delinea las superficies acristaladas, proporcionando a la estructura la máxima resistencia y estabilidad. La partición irregular realza las cualidades del cristal y mejora sus transparencias veladas. La amplia flexibilidad de diseño permite crear composiciones personalizadas, ideales para contextos domésticos, profesionales, de hostelería y de comercio.

RU Раздвижная система Maxi отличается алюминиевой решеткой, которая разделяет стеклянные поверхности, придавая конструкции максимальную прочность и устойчивость. Неравномерные секции подчеркивают свойства стекла и его прозрачность. Благодаря очень гибкому дизайну можно создавать композиции по индивидуальному заказу, идеально подходящие для жилых, офисных, гостиничных и торговых помещений.

汉语 覆上铝网格的玻璃板材为 Maxi 推拉门系统的设计特色, 为结构提供强度和稳定性。不规则纹理衬托出玻璃的极佳质量与丝雾般的透明感。极高的设计灵活性带来各式各样的定制组合, 是居家、酒店、零售和专业性办公空间的理想选择。



EN Maxi has an aluminium frame covered in noce, rovere, and rovere termotrattato, or in aluminium in brown and all colours of the Ecolosystem. The glass is available in 74 finishings, and some modules finishings can be supplied in a different colour on request for an exclusive look. The sliding panels of the Maxi system are always custom made in height and width.

IT Maxi presenta una struttura in alluminio rivestito in noce, rovere e rovere termotrattato o in alluminio brown e in tutti i colori Ecolosystem. I vetri sono disponibili in 74 finiture, con la possibilità di personalizzare alcuni moduli con un vetro di colore differente, per una resa estetica esclusiva. I pannelli scorrevoli del sistema Maxi vengono realizzati sempre su misura in altezza e larghezza.

DE Die Schiebewände des Maxi-Systems werden in Höhe und Breite immer nach Maß gefertigt. Das Maxi-System besitzt ein Gestell aus Aluminium in der Farbe Noce, Rovere und Rovere termotrattato oder ist in Aluminium-Brown, Bronzo, Grafite und Nero erhältlich. Die Gläser sind in 74 Oberflächen erhältlich, wobei einige Spiegel mit einem andersfarbigen Glas versehen werden können.

FR Maxi présente une structure en aluminium revêtu noce, rovere et rovere termotrattato ou en aluminium brown et dans toutes les couleurs Ecolosystem. Le verre est disponible en 74 finitions. Il est possible de personnaliser certains modules avec un verre de couleur différente, pour un rendu esthétique exclusif. Les panneaux coulissants du système Maxi sont toujours réalisés sur mesure en hauteur et en largeur.

ES Maxi presenta una estructura en aluminio revestido en noce, rovere, rovere termotrattato, brown y en todos los colores Ecolosystem. Los cristales están disponibles en 74 acabados, con la posibilidad de personalizar algunos módulos con un cristal de color diferente, para un resultado estético exclusivo. Los paneles correderos del sistema Maxi se fabrican siempre a medida en altura y anchura.

RU Система Макси представляет собой алюминиевую конструкцию, выполненную с отделкой из ореха, дуба, термообработанного дуба, а также отделкой коричневого цвета и всех цветов Ecolosystem. Используются 74 варианта отделки для остекления, по индивидуальному заказу можно выполнить остекление из стекол разного цвета. Раздвижные панели системы Макси всегда изготавливаются по индивидуальным размерам высоты и ширины.

汉语 Maxi 系列的铝框饰面可选用胡桃木、橡木、热处理橡木、铝原色和各种 Ecolosystem 色。现有 74 种玻璃饰面可供选择，且可使用不同颜色的玻璃定制某些款式，以达到独特的美学效果。Maxi 系列的滑动门板之高度和宽度均按尺寸定制。



MAXI GRID
Structure: 19 rovere termotrattato
Glass: 65 bronzo trasparente, 04 acidato bronzo
Handle: 302 grafite, 19 rovere termotrattato

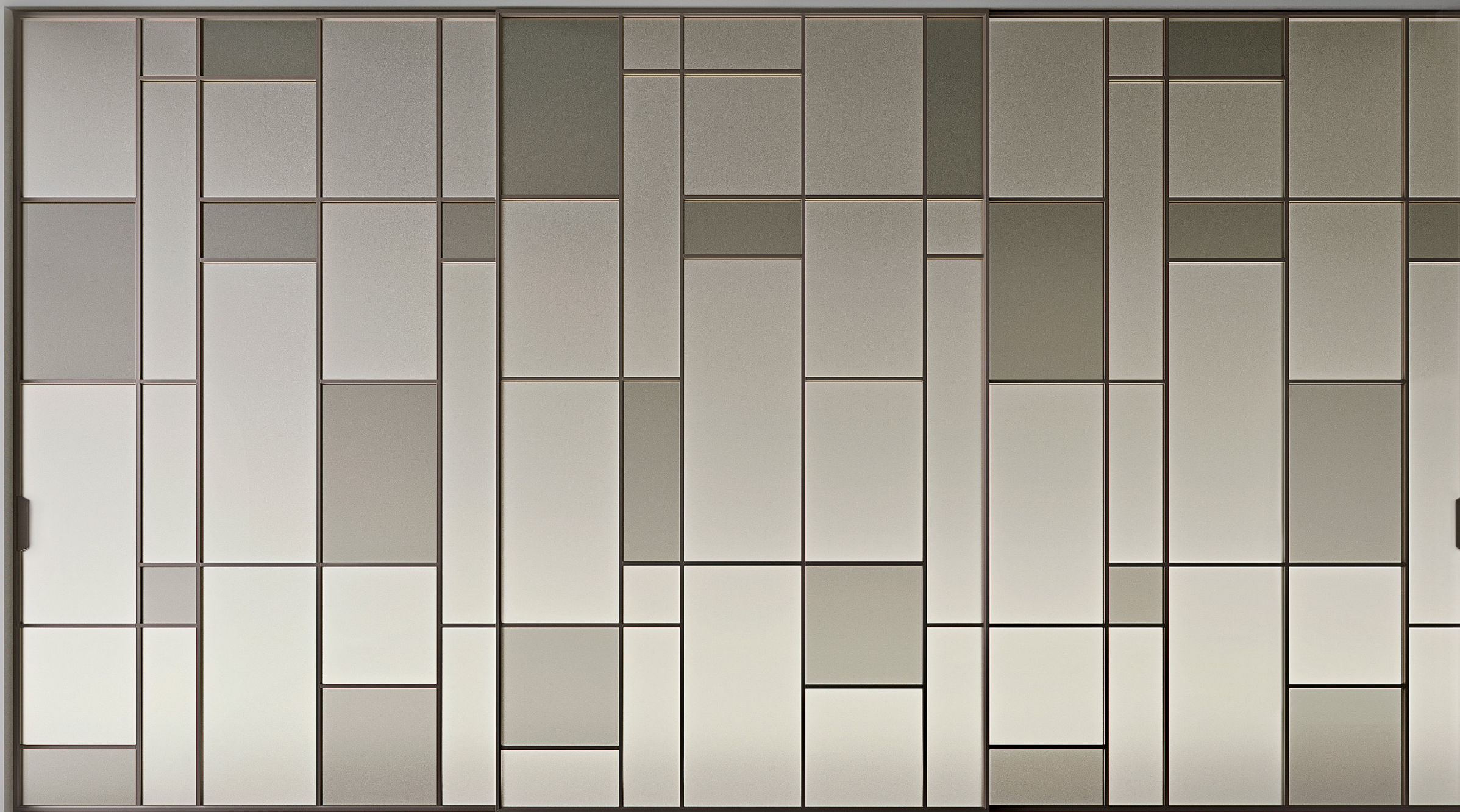



MAXI GRID
Structure: 15 noce
Glass: 590 trasparente sahara
Handle: 303 bronzo, 15 noce

In this photo
Suspended cabinet: Self bold

EN Maxi is distinguished by quality and attention to detail: the die-cast metal handle is fitted with a spring mechanism designed for a better grip when opening and closing the door. The glass in the sahara finishing is available in a transparent or satin version and emphasises the discreet and elegant undulation of the glass to create a textured effect.

IT Qualità e cura dei dettagli caratterizzano Maxi: la maniglia in pressofusione metallica è dotata di un meccanismo con molle pensato per migliorare l'impugnatura nella fase di apertura e chiusura della porta. Il vetro in finitura sahara, disponibile in versione trasparente o satinata, è caratterizzato dalla discreta ed elegante ondulatione del vetro per un effetto materico.

DE Qualität und Liebe zum Detail zeichnen Maxi aus: Der Griff aus Metalldruckguss ist mit einem Federmechanismus ausgestattet, der den Halt beim Öffnen und Schließen der Tür verbessert. Das Glas bei der Oberfläche Sahara, das in transparenter oder satinierter Ausführung erhältlich ist, zeichnet sich durch die diskrete und elegante Wölbung des Glases, das einen strukturierten Effekt ermöglicht.

FR Qualité et souci du détail caractérisent Maxi: la poignée en métal moulé sous pression est dotée d'un mécanisme à ressorts conçu pour améliorer la prise en main lors de l'ouverture et de la fermeture de la porte. Disponible en version transparente ou satinée, le verre en finition sahara se caractérise par une ondulation discrète et élégante, pour un effet matière.

ES La calidad y la atención al detalle caracterizan Maxi: el tirador de metal fundido a presión está equipado con un mecanismo de resorte diseñado para mejorar el agarre al abrir y cerrar la puerta. El cristal en acabado sahara, disponible en versión transparente o satinado, se caracteriza por la discreta y elegante ondulación del cristal que genera un efecto matérico.

RU Система Maxi выделяется качеством и вниманием к деталям: литая металлическая ручка снабжена пружинным механизмом, улучшающим захват при открывании и закрывании двери. Стекло с отделкой sahara прозрачного или матированного исполнения отличается еле заметной и элегантной волнистостью, создающей рельефный эффект.

汉语 Maxi 以其品质和对细节的关注而著称：压铸成型的金属把手配有弹簧装置，用于增强推拉门板时的手感。可选透明玻璃或缎面玻璃，其表面处理为 Sahara，它以内敛、雅致的水波纹理尤为特色。









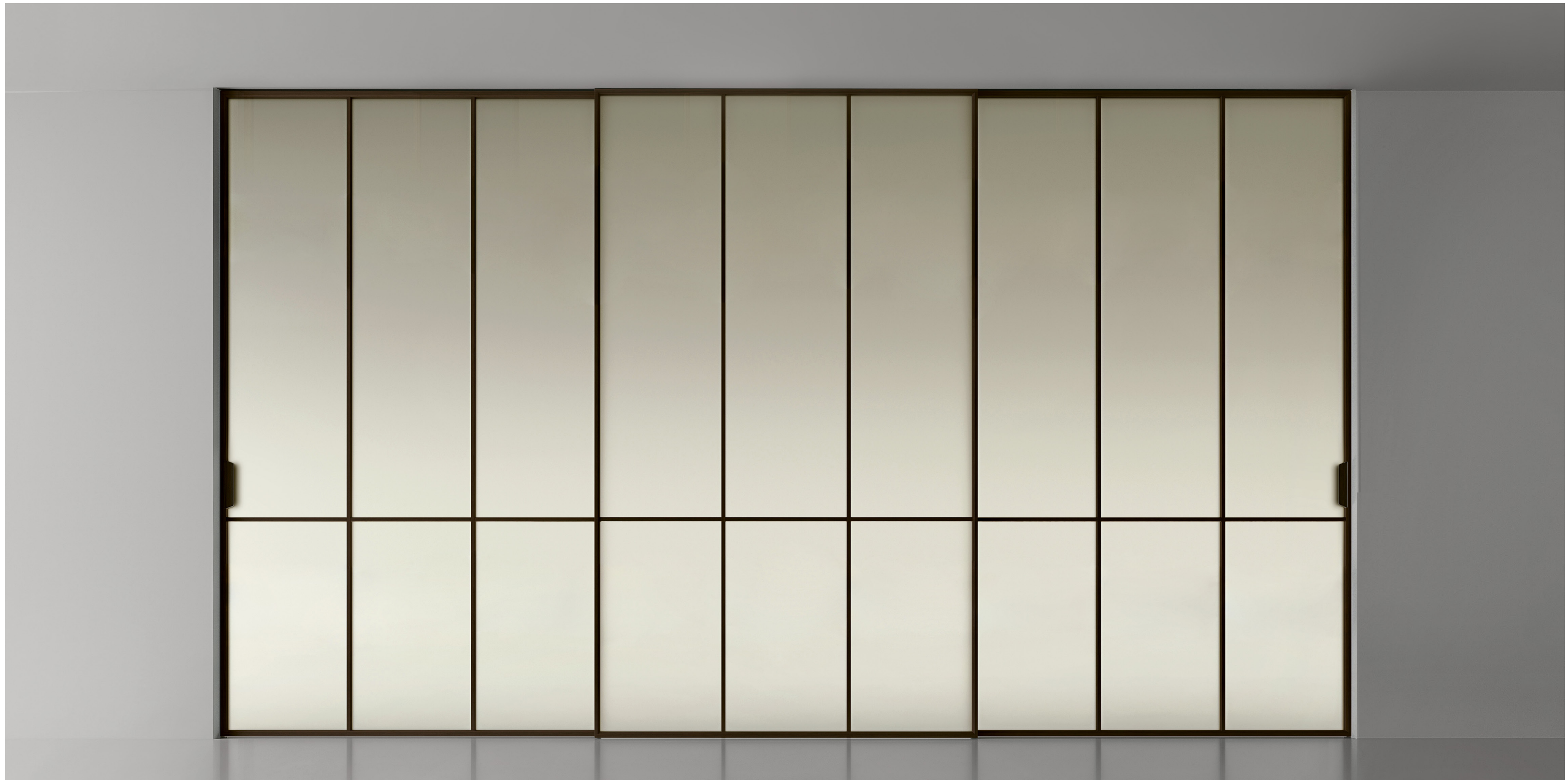



EXCLUSIVE TECHNICAL FEATURES



1. Extruded aluminium frame sp. 50 mm (alloy EN AW-6060) with real wood finishing.
2. Tempered glass, 6 mm thick, conforms to UNI EN 12150, UNI 7697 and UNI EN 12600 standards.

DIMENSIONS

Maxi grid

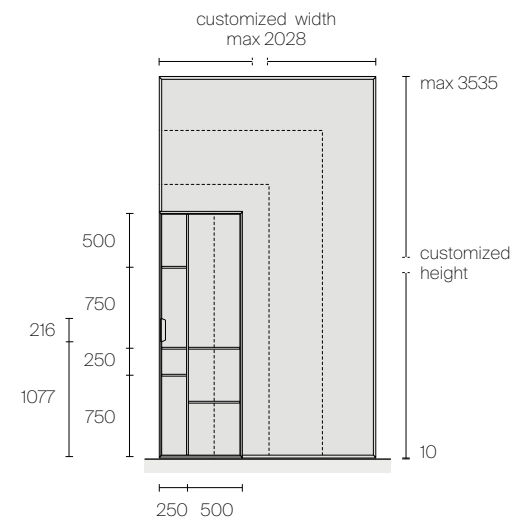

Maxi regular

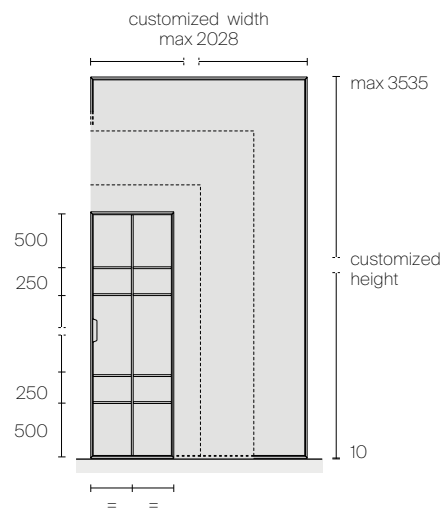

Maxi plus

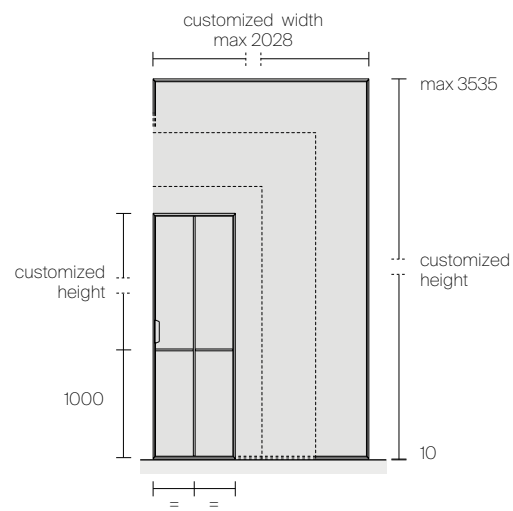

Maxi pure

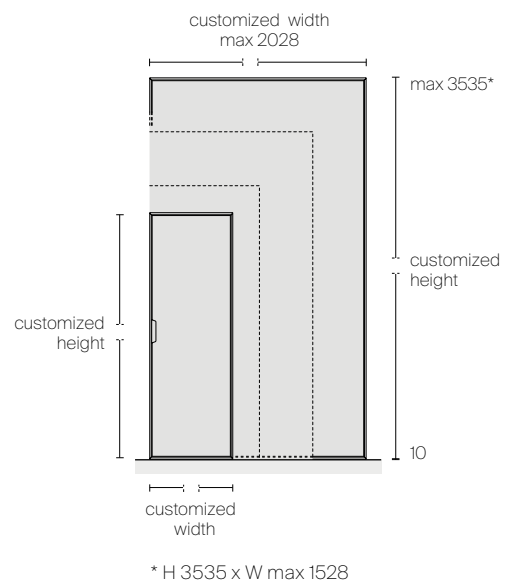

AESTHETICAL TYPOLOGIES

Maxi grid

Typology A: panel with single-coloured glass

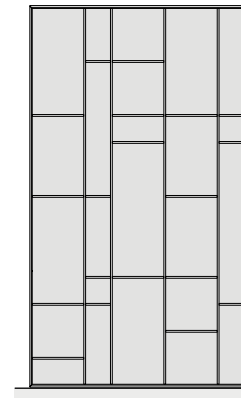

Typology B: panel with two-tone glass

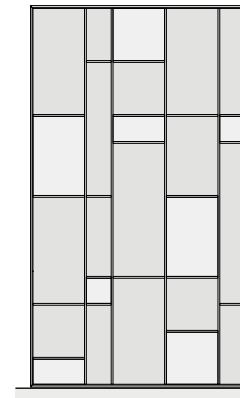

Typology C: panel with two-tone glass

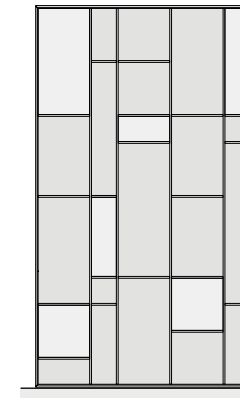

Maxi regular

Typology A: panel with single-coloured glass

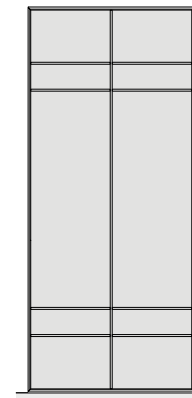

Typology B: panel with two-tone glass

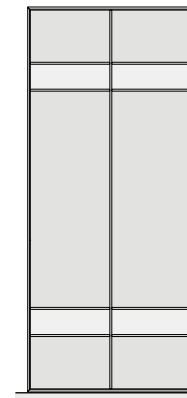

Maxi plus

Panel with single-coloured glass

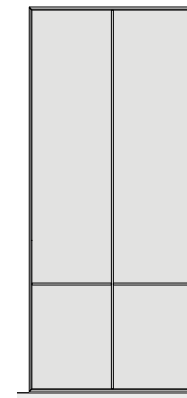

Maxi pure

Panel with single-coloured glass

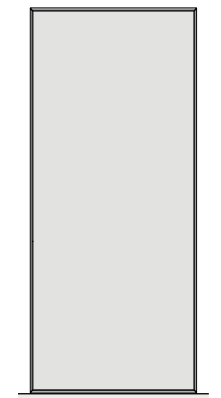

HANDLES

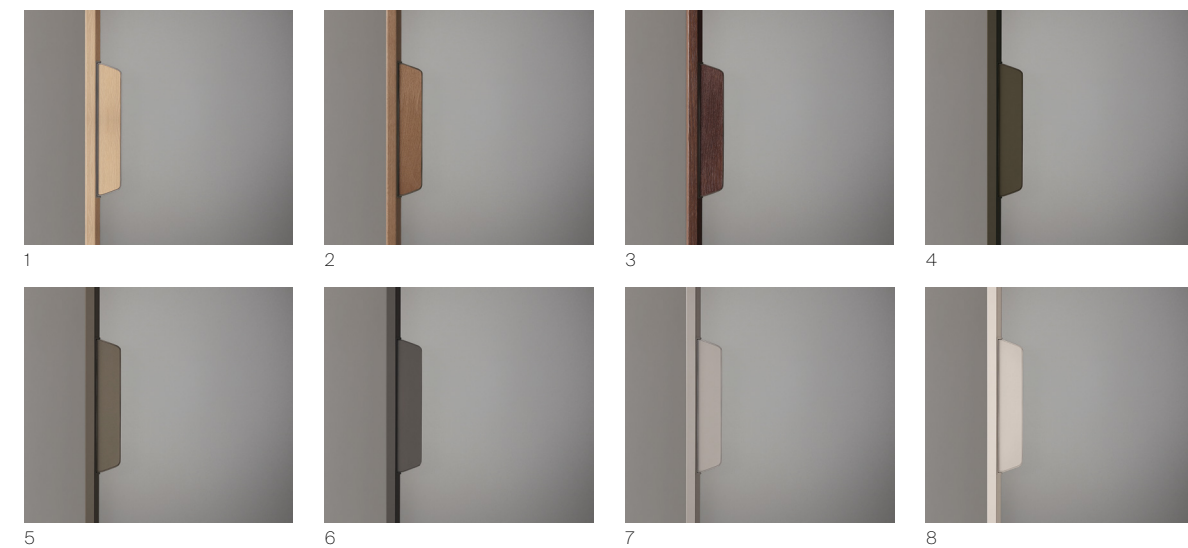

1. Handle in 304 platino and 711 rovere
2. Handle in 303 bronzo and 15 noce
3. Handle in 302 grafite and 19 rovere termotrattato
4. Handle in 14 brown
5. Handle in 303 bronzo
6. Handle in 302 grafite
7. Handle in 304 platino
8. Handle in 53 bianco neve

Structure and handle

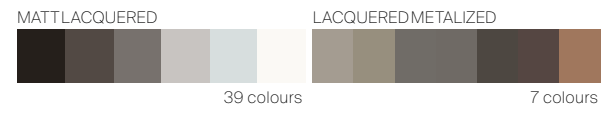

Glasses

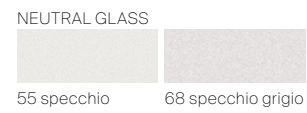
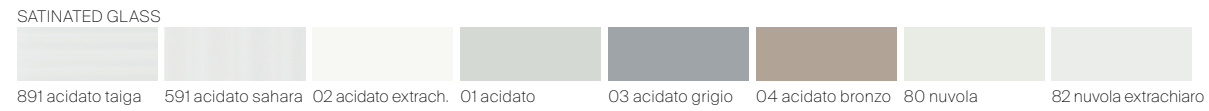
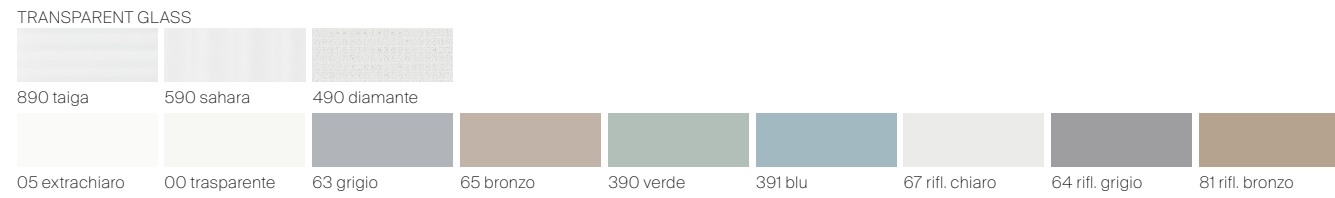
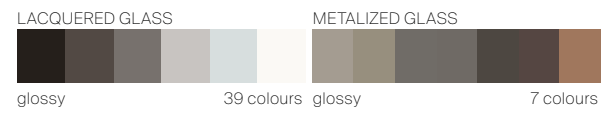

Structure and handle

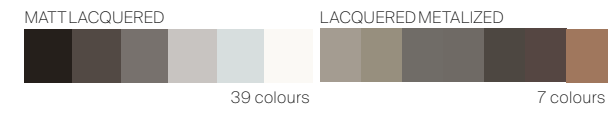

Glasses

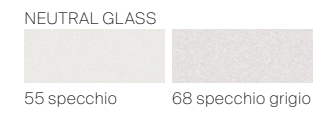
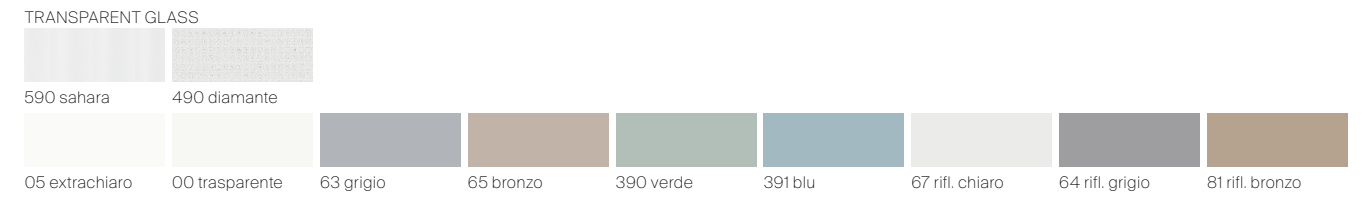
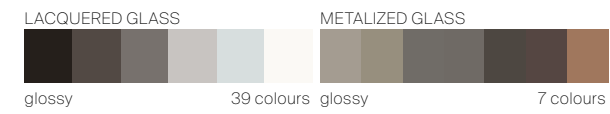

QUALITY AS THE MAIN PURPOSE, ALWAYS AND IN EVERY ASPECT. WITH THIS MISSION RIMADESIO IS CONSTANTLY SEARCHING FOR SOLUTIONS TO IMPROVE ITS OWN ECOLOGICAL STANDARDS.

OBJECTIVE OBTAINED THANKS TO THE USE OF PRECIOUS AND RECYCLABLE MATERIALS, TO THE ABSENCE OF SUBSTANCES THAT CAN BE TOXIC TO HUMANS OR HARMFUL TO THE ENVIRONMENT IN EVERY PHASE OF THE PRODUCTIVE PROCESS, TO THE USE OF TECHNOLOGY AND EVOLVED MACHINERY, POWERED BY CLEAN ENERGY DERIVED FROM PHOTOVOLTAIC SYSTEMS, INSTALLED ON THE GIUSSANO HEADQUARTERS ROOF.

ALUMINIUM, GLASS, WOOD: FULLY RECYCLABLE AND PARTLY ALREADY RECYCLED MATERIALS.

PROOFS OF A REINFORCED GREEN DNA AND WIDE COHERENCE, SIGNALS OF A CONTINUOUS RESEARCH AND A GLANCE TOWARDS THE FUTURE, THAT TAKES SHAPE IN THE TECHNOLOGICAL INNOVATION OF SYSTEMS, DOORS AND FURNITURE, MADE WITH THE AWARENESS OF WANTING TO ENTRUST HUMANS ONLY WITH HIGH VALUE-ADDED ACTIVITIES.

EXCELLENCE SUSTAINABILITY PROJECT

IT Perseguire la qualità, sempre, sotto tutti gli aspetti. Con questa mission Rimadesio ricerca costantemente soluzioni volte a migliorare i propri standard qualitativi ecologici. Obiettivo ottenuto sinergicamente, grazie all'utilizzo di materiali preziosi e riciclabili, all'assenza di sostanze tossiche per l'uomo e nocive per l'ambiente in ogni fase del processo produttivo, all'impiego di tecnologie e macchinari evoluti alimentati con energia pulita proveniente da impianti fotovoltaici, installati sulla copertura dell'headquarter di Giussano. Alluminio, vetro, legno, materiali totalmente riciclabili e in parte già riciclati, ma anche le vernici prive di solventi di Ecoloursystem e i sistemi di imballaggio ecologici. Testimonianze di un dna green consolidato e di una coerenza trasversale, segnali di una continua attività di ricerca e di uno sguardo sempre proteso al futuro che si declina nell'innovazione tecnologica di sistemi, porte ed arredi, realizzati con la consapevolezza di voler affidare all'uomo solo attività dall'alto valore aggiunto.

DE Stets um Qualität bemüht, und zwar in allen Bereichen. Mit dieser Mission im Blick sucht Rimadesio laufend nach Lösungen, um seine ökologischen Qualitätsstandards zu verbessern. Dieses Ziel wurde dank der Verwendung wertvoller und wiederverwertbarer Materialien, dem Verzicht auf für den Menschen giftige und umweltschädliche Stoffe in jeder Phase des Produktionsprozesses und dem Einsatz fortschrittlicher Technologien und Maschinen, die mit sauberer Energie aus den auf dem Dach des Giussano-Hauptsitzes installierten Photovoltaikanlagen betrieben werden, synergetisch erreicht. Aluminium, Glas, Holz, vollständig recycelbare und teilweise bereits recycelte Materialien, aber auch die lösungsmittelfreien Farben von Ecoloursystem und umweltfreundliche Verpackungssysteme. Ein Zeugnis einer fundierten grünen DNA und einer transversalen Kohärenz, Zeichen einer kontinuierlichen Forschungstätigkeit und eines stets in die Zukunft gerichteten Blicks, der sich in der technologischen Innovation von Systemen, Türen und Einrichtungsgegenständen ausdrückt, die in dem Bewusstsein realisiert werden, den Menschen nur Tätigkeiten mit hohem Mehrwert anzuvertrauen.

FR Poursuivre la qualité, toujours, et à tous les égards. Avec cette mission Rimadesio recherche constamment de solutions au fin d'améliorer ses normes de qualité écologique. Objectif atteint, grâce à l'utilisation de matériaux précieux et recyclables, l'absence à chaque étape de la production de substances toxiques nocives pour l'homme et l'environnement, l'utilisation de technologies et des machines avancées alimentées par l'énergie solaire après l'installation sur le toit de l'usine à Giussano de systèmes photovoltaïques. Aluminium, verre, bois, des matériaux entièrement recyclables et déjà en partie recyclés, mais aussi peinture Ecoloursystem sans solvants et systèmes d'emballage respectueux de l'environnement. Témoignages d'un adn "vert" consolidé et d'une cohérence transversale, signes de recherche continue et d'une tendance à regarder en avant, qui correspond bien à l'innovation technologique des systèmes, des portes et des meubles, réalisés avec la conscience que l'apport de l'homme dans la production ne peut qu'avoir une valeur ajoutée.

ES Perseguir la calidad, siempre, en todos los aspectos. Con esta misión Rimadesio busca constantemente soluciones destinadas a mejorar sus estándares de calidad ecológica. Objetivo conseguido sinérgicamente, gracias al uso de materiales preciosos y reciclables, a la ausencia de sustancias tóxicas para los seres humanos y nocivas para el medio ambiente en cada etapa del proceso de producción, al uso de tecnologías y máquinas avanzadas alimentadas por energía limpia a partir de sistemas fotovoltaicos, instalados en la cobertura del headquarter de Giussano. Aluminio, cristal, madera, materiales completamente reciclables y, en parte, ya reciclados, sino también las pinturas Ecoloursystem libres de disolventes y los sistemas de embalaje ecológicos. Testimonios de un adn green consolidado y una coherencia transversal, señales de una continua investigación y de una vista siempre tendida al futuro que se declina en la innovación tecnológica de sistemas, puertas y muebles, realizados con el conocimiento que desea confiar al hombre sólo actividades de alto valor añadido.

RU Обеспечение качества всегда и во всем. И, в том числе, для достижения этой цели Компания Rimadesio находится в постоянном поиске решений, направленных на улучшение экологических стандартов качества. Эта цель была достигнута благодаря использованию на каждом этапе производственного процесса ценных материалов, пригодных для вторичной переработки, отсутствию токсичных для человека и вредных для окружающей среды веществ, а также благодаря внедрению передовых технологий и оборудования, работающего на чистой энергии от фотоэлектрических систем, установленных на крыше штаб-квартиры компании в г. Джуссано. Компания использует такие материалы, как алюминий, стекло, дерево – полностью перерабатываемые и уже частично переработанные материалы, краски Ecoloursystem, не содержащие растворителей, а также экологически упаковку. Свидетельство консолидированной экологичности и непрерывной последовательности, исследовательской деятельности и взгляда, всегда устремленного в будущее, что выражается в технологических инновациях систем, дверей и мебели, произведенных с осознанием того, что человеку стоит поручать только деятельность с высокой добавленной стоимостью.

汉语 至始至终追求全方位的卓越品质。Rimadesio 肩负使命，不断探索精进生态质量标准的解决方案。品牌目标之达成有赖于珍贵的可回收材料，该材料在所有制造阶段皆不会产生危害人体和环境之有毒物质，同时结合业界前沿的技术以及先进机械装置；而位于朱塞诺 (Giussano) 品牌总部建筑屋顶上的光伏发电设备为上述之机械装置供给干净的能源。除了可完全回收和已部分回收的铝材、玻璃、木材等材料之外，还有环保色彩系统 (Ecoloursystem) 的无溶剂涂料和生态环保型包装。深植的绿色 DNA、跨领域的协同性、持续的研究工作以及具前瞻性的未来展望皆体现在家具系统、各式门类 and 家具配件的技术创新上，其本着信赖人类才能胜任高附加价值活动的意念研发而成。

GUIDE TO RIMADESIO QUALITY

TEMPERED GLASSES

Single tempered glasses cooked at a temperature of 650 °C. Mechanical resistance 5 times superior in comparison to a normal glass. In case of breaking it crumbles in harmless tiny fragments. In accordance with the UNI EN 12150, UNI 7697 and UNI EN 12600 rules with reference to the security of glasses for decoration purposes.

LAMINATED GLASSES

Double glasses. Between the two glasses a thin plastic film is inserted. Transparent and invisible, it perfectly sticks to both surfaces. Both surfaces are perfectly smooth.Resistance to breaking in accordance with the UNI EN ISO 12543, UNI 7697 and UNI EN 12600 rules. The plastic film withholds the fragments in case of breaking.

GLASS WITH METAL NET AND MESH

Double laminated glasses. Between the two extra-clear glasses and two thin plastic films a micronet fabric is inserted. Through a sophisticated process a metal layer is applied on the fabric, thus creating a characteristic effect of semi transparency. The reflections of the light on the surface of the metallic net are provided by using an extra-clear float glass, which allows maximum transparency and high light transmissions, thanks to the low content of iron oxides. Following the process of hot stratification, the fabric might show minor wave effect, which give the material its characteristic materic and natural look.

ECOLORSYSTEM LACQUERED GLASSES

Ecolorsystem is the name that distinguishes the exclusive Rimadesio lacquered glass collection in glossy and matt finishing. Ecological colours produced using exclusively water paints of latest generation, cooked at 110° C. A production technology in the area of glass, with a fully robotised in-house plant that ensures very high quality results and a low environmental impact work cycle. Corrosion resistance conforms to the UNI EN ISO 9227 standard. Temperature fluctuation resistance conforms to the UNI 9429 standard. The colour is inside the double glass, safe from stains, dust and humidity. The thickness of the glass creates an exclusive "depth" effect.

VETRI TEMPERATI

Vetri singoli, sottoposti al trattamento della tempra ovvero ad una cottura alla temperatura di 650 °C. Resistenza meccanica di 5 volte superiore rispetto ad un vetro normale. In caso di rottura si sbriciola in minuti frammenti inoffensivi. Conformi alle norme UNI EN 12150, UNI 7697 e UNI EN 12600 in materia di sicurezza per i vetri d'arredamento.

VETRI STRATIFICATI

Vetri doppi. Fra i due vetri è inserita una sottile pellicola di materiale plastico, trasparente ed invisibile, che aderisce completamente alle due superfici. Entrambe le superfici sono perfettamente lisce. Resistenza alla rottura conforme alle norme UNI EN ISO 12543, UNI 7697 e UNI EN 12600. La pellicola di materiale plastico in caso di rottura trattiene i frammenti.

VETRI STRATIFICATI RETE, MAGLIA E FIBRA

Vetri doppi stratificati. Tra i due vetri extra-chiari e le due sottili pellicole in materiale plastico, è inserito un tessuto in microrete sul quale, tramite un sofisticato processo di materizzazione, viene depositato uno strato metallico che crea un caratteristico effetto di semitrasparenza. Le riflessioni della luce sulla superficie della rete metallizzata sono ottenute con l'utilizzo del vetro float extrachiaro che, grazie al basso contenuto di ossidi di ferro, garantisce la massima trasparenza e un'elevata trasmissione luminosa. Il tessuto, a seguito del processo di stratifica a caldo, può presentare delle leggere ondulazioni che conferiscono al materiale il suo caratteristico aspetto materico e naturale.

VETRI LACCATI ECOLORSYSTEM

Ecolorsystem è la denominazione che contraddistingue l'esclusiva collezione di vetri laccati Rimadesio, disponibili in finitura lucida e opaca. Colori ecologici perchè prodotti utilizzando esclusivamente vernici all'acqua di ultima generazione, con cottura a 110°C. Una tecnologia produttiva all'avanguardia nell'ambito del vetro, con impianti interni totalmente robotizzati che assicurano risultati di altissima qualità e un ciclo di lavorazione a basso impatto ambientale. Resistenza alla corrosione conforme alla norma UNI EN ISO 9227. Resistenza agli sbalzi di temperatura conforme alla norma UNI 9429. Colori inalterabili nel tempo perchè applicati sulla superficie interna del vetro, al sicuro da macchie, polvere e umidità. Lo spessore del vetro crea un esclusivo effetto di "profondità".

TEMPERIERTES GLAS

Einzelgläser, die einer Härtingsbehandlung oder einer Kochtemperatur von 650 °C unterzogen wurden. Mechanische Beständigkeit 5 mal höher als bei normalem Glas. Im Bruchfall zerbröckeln harmlose Bruchstücke in Minuten. Entspricht den Normen UNI EN 12150, UNI 7697 und UNI EN 12600 für die Sicherheit von Möbelgläser.

SCHICHTGLAS

Doppelgläser. Zwischen den beiden Gläsern befindet sich ein dünner Film aus transparentem und unsichtbarem Kunststoff, der vollständig an den beiden Oberflächen haftet. Beide Oberflächen sind komplett glatt. Die Bruchfestigkeit entspricht den Normen UNI EN ISO 12543, UNI 7697 und UNI EN 12600. Die Kunststofffolie bewahrt im Bruchfall die Bruchstücke.

SCHICHTGLAS MIT METALLNETZ, GLASGITTER UND FASER

Hierbei handelt es sich um Doppel-schichtgläser. Zwischen den zwei Extralight-Glasscheiben und den beiden unsichtbaren Plastikfolien wird ein Metallnetz eingesetzt. Das kreiert einen besonderen halbttransparenten Effekt. Der Wiederschein des Lichtes auf der Oberfläche des Metallnetzes wird durch die Verwendung von Extralight Float Glas erzielt. Dank eines kleinen Anteils von Eisenoxid haben wir die maximale Lichtdurchlässigkeit und eine sehr hohe Lichtübertragung erzielen können. Das Netz kann nach dem unter Hitze durchgeführten Schichtungsverfahren leichte Welle aufweisen, was dem Material ein natürliches Aussehen verleiht.

LACKIERTE GLÄSER ECOLORSYSTEM

Ecolorsystem ist der Name der lackierten Glas-Kollektion von Rimadesio in der glänzend und matte Ausführung verfügbar. Absolut oekologische Farben, da die modernsten Lackierungen, auf Wasser-Basis, an einer Temperatur von 110° gekocht werden. Eine fortschrittliche Produktionstechnik in der Glasverarbeitung auf einer vollautomatisierten Anlage, die Ergebnisse höchster Qualität und gleichzeitig umweltfreundliche Verarbeitungsverfahren gewährleistet. Korrosion-sprüfung gemäß Bestimmung UNI EN ISO 9227. Temperaturwechselprüfung gemäß Bestimmung UNI 9429. Unverändliche Farben da die Farbung sich im Innen des Doppelglases, geschützt vor Staub, Kratzen und Feuchtigkeit, befindet. Die Dicke des Glases erzeuge eine einzigartige Tiefwirkung.

VERRES TREMPÉS

Verres simples, soumis au traitement de trempe et donc à une température de cuisson de 650 °C. Résistance mécanique 5 fois supérieure à celle du verre normal. En cas de rupture, des fragments inoffensifs s'effritent en quelques minutes. Conforme aux normes UNI EN 12150, UNI 7697 et UNI EN 12600 pour la sécurité des verres pour les meubles.

VERRES STRATIFIÉS

Double verres. Entre les deux verres se trouve une fine pellicule de matière plastique, transparente et invisible, qui adhère complètement aux deux surfaces. Les deux surfaces sont parfaitement lisses. La résistance aux ruptures est conforme aux normes UNI EN ISO 12543, UNI 7697 et UNI EN 12600. La pellicule retient les fragments en cas de rupture.

VERRE FEUILLETÉ AVEC NET, MAILLE ET FIBRA

Double verre stratifié. Entre les deux verres extra clair et les deux films fins de matière plastique un tissu en micro maille est ajouté. A travers un procédé avancé de materisation un couche métallique est déposé sur ce tissu, créant un effet caractéristique translucide. Les reflets de la lumière sur la surface de la maille métallique sont obtenus avec l'utilisation du verre float extra clair, qui, grâce à un faible teneur de oxydes de fer, permet un maximum de transparence et de transmission de la lumière. Suite au procédé de stratification à chaud, le tissu peut présenter de petites ondulations, qui apportent au matériau son aspect caractéristique et naturel.

VERRES LAQUÉS ECOLORSYSTEM

Ecolorsystem est le nom qui caractérise la collection exclusive de verres laqués de Rimadesio disponibles en finition brillante et mate. Couleurs écologiques, parce que produites en utilisant exclusivement vernis à l'eau de dernière génération, cuites à 110°. Une technologie de production avant-gardiste dans le domaine du verre, avec des équipements internes entièrement robotisés qui assurent des résultats de grande qualité et un cycle de production ayant un impact très faible sur l'environnement. Résistance à la corrosion conformément à la norme UNI EN ISO 9227. Résistance aux écarts de température conformément à la norme UNI 9429. Couleurs inaltérables parce qu'ils sont appliqués dans la surface interne du verre, pour protéger de la poussière humidité et taches. L'épaisseur du verre crée un exclusif effet profondeur.

CRISTALES TEMPLADOS

Vidrios simples, sometidos al tratamiento de templado a una temperatura de cocción de 650 °C. Resistencia mecánica de 5 veces mayor que el vidrio normal. En caso de rotura, se desmoronan fragmentos inofensivos. Conforme a las normas UNI EN 12150, UNI 7697 y UNI EN 12600 en materia de seguridad para los cristales en el amueblamiento.

CRISTALES ESTRATIFICADO

Vidrios dobles. Entre los dos vidrios hay una película fina de material plástico, transparente e invisible, que se adhiere completamente a las dos superficies. Ambas superficies son perfectamente lisas. La resistencia a la rotura cumple con las normas UNI EN ISO 12543, UNI 7697 y UNI EN 12600. La película de plástico en caso de rotura retiene los fragmentos.

CRISTALES ESTRATIFICADOS RED METÁLICA, MAILLA Y FIBRA

Cristales dobles estratificados. Entre los dos cristales extraclaros y las dos capas sintéticas, está inserido en un tejido de microred en el que, a través de un sofisticado proceso se deposita una característica de efecto semitransparente. Los reflejos de la luz sobre la superficie de la red metálica se proporcionan con el uso del vidrio float extraclaro que, gracias a su bajo contenido en óxidos de hierro, asegura la máxima transparencia y una alta transmisión de luz. El tejido, siguiendo el proceso de estratificación en caliente, puede presentar ligeras ondulaciones que dan al material su aspecto característico natural.

CRISTALES LACADOS ECOLORSYSTEM

Ecolorsystem es la denominación que marca la exclusiva colección de los cristales lacados Rimadesio, disponibles en acabado brillante y mate. Colores ecológicos porque productos utilizando exclusivamente pinturas al agua de última generación, con cocción a 110°. Una tecnología productiva a la vanguardia en el ámbito del cristal, con unas instalaciones internas totalmente robotizadas que aseguran resultados de altísima calidad y un ciclo de tratamiento respetuoso del medio ambiente. Resistencia a la corrosión conforme a la norma UNI EN ISO 9227. Resistencia a las variaciones de temperatura conforme a la norma UNI 9429. Colores inalterables en el tiempo porque aplicados en la superficie interior del cristal, al resguardo de manchas, polvo y humedad. El grosor del cristal crea un exclusivo efecto de "profundidad".

ЗАКАЛЕННОЕ СТЕКЛО

Механическая прочность одинарных стекол, подвергнутых закалке, т.е. обжигу при температуре 650°С, в 5 раз выше, чем у обычного стекла. Если такое стекло разбить, оно рассыпется на мелкие неопасные осколки. Соответствует стандартам безопасности UNI EN 12150, UNI 7697 и UNI EN 12600 для мебельного стекла.

МНОГОСЛОЙНОЕ СТЕКЛО

Двойные стекла. Тонкая, прозрачная и невидимая пластиковая пленка прокладывается между двумя стеклами и полностью приклеивается к обеим поверхностям. Обе поверхности идеально гладкие. Проверка прочности на разрыв была выполнена в соответствии со стандартами UNI EN ISO 12543, UNI 7697 и UNI EN 12600. Эта пленка способна удерживать осколки разбившегося стекла.

МНОГОСЛОЙНОЕ СТЕКЛО, СТЕКЛО С СЕТКОЙ

Многослойное двойное стекло. Между двумя сверхпрозрачными стеклами и двумя тонкими пластиковыми пленками вставляется микросетчатое полотно, на которое в ходе сложного производственного процесса наносится металлический слой, благодаря чему и формируется характерный полупрозрачный эффект. Отражение света на поверхности металлизированной сетки достигается за счет использования сверхчистого флот-стекла, которое из-за низкого содержания оксида железа гарантирует максимальную прозрачность и высокую светопропускную способность. В результате процесса наслаивания в горячем виде полотно приобретает небольшие волнистости, которые придают материалу характерную текстуру и натуральный вид.

ЛАКИРОВАННОЕ СТЕКЛО

ECOLORSYSTEM Ecolorsystem — это название эксклюзивной коллекции лакированного стекла Rimadesio, доступной в глянцевой и матовой отделке. Коллекция характеризуется мягкими спокойными цветами, поскольку при их производстве используются только краски последнего поколения на водной основе, запекаемые при температуре 110°С. В стекольной промышленности в настоящее время внедряются современные производственные технологии, полностью роботизированные заводы, обеспечивающие высокое качество и незначительное воздействие на окружающую среду. Коррозионная стойкость соответствует требованиям положений стандарта EN ISO 9227. Устойчивость к изменениям температуры соответствует требованиям стандарта UNI 9429. Цвет характеризуется исключительной долговечностью, поскольку краски наносятся на внутреннюю поверхность стекла, защищенную от пятен, пыли и влаги. Толщина стекла создает уникальный эффект «глубины».

钢化玻璃 单片玻璃通过淬火工艺,即经 650 °C 高温烧制而成,其机械阻力相较于普通玻璃高出 5 倍。钢化玻璃破裂时会碎成不易伤人的细小碎片。符合家具玻璃安全材质 UNI EN 12150、UNI 7697 以及 UNI EN 12600 的标准。

夹层玻璃 双层玻璃。在两片玻璃之间夹有一层纤薄、透明、无形的塑料薄膜,其完全贴合两片玻璃的表面。两片玻璃的表面皆光滑无比。其抗裂性能符合 UNI EN ISO 12543、UNI 7697 以及 UNI EN 12600 的标准。玻璃破裂时,其碎片会粘在塑料薄膜上,裂而不散。

环保色彩系统 (Ecolorsystem) 烤漆玻璃

网夹层玻璃、网格夹层玻璃和纤维夹层玻璃 双层夹层玻璃。在两片超清玻璃和两层纤薄的塑料薄膜之间夹入一层微型网状织物,一道细腻的材质加工工艺,会在织物上覆盖一层金属并创造出半透明的特殊效果。使用超清浮法玻璃产出金属网表面的光线反射,因玻璃的氧化铁含量低,可确保最大透明度和高透光率。通过热分层加工工艺,夹入的织物会稍有不平整的现象,从而呈现出具有特色的材质纹理和自然感的外观。

环保色彩系统 (Ecolorsystem) 烤漆玻璃

Ecolorsystem 为 Rimadesio 烤漆玻璃独家系列的名称,有亮面和哑光两种表面处理可供选择。由于仅使用最新一代的水性涂料搭配 110°C 烘烤工序完成而被称为生态环保性色彩;其为超前玻璃业界的生产技术,而全机器人化的内部设备确保极高的产品质量和低环境冲击的加工循环。其抗腐蚀程度符合 UNI EN ISO 9227 的标准。其抗温度急变性符合 UNI 9429 的标准。因色彩涂层夹于玻璃内层,因此不会褪色且不受脏污、灰尘和湿气的影响。玻璃的厚度创造出一种独特的“深度”效果。

ECOLORSYSTEM LACQUERED GLASS

GLOSSY MATT		GLOSSY MATT		GLOSSY MATT		GLOSSY MATT		GLOSSY MATT		GLOSSY MATT			
305	138 cipria	45	97 avorio	59	105 grigio chiaro	40	115 grigio cenere	53	95 bianco neve	50	108 bianco latte		
51	113 nocciola	52	107 corda	56	98 lino	312	145 grigio seta	47	96 grigio perla	78	114 sabbia		
306	139 terracotta	85	130 tufo	310	143 creta	38	121 azzurro cera	36	117 blu Londra	74	110 canapa		
76	116 rosso india	308	141 pepe	317	600 grigio artico	35	100 blu notte	39	122 verde inglese	73	109 giallo kashmir		
75	129 amaranto	309	142 sandalo	88	132 grigio scuro	86	131 blu oceano	314	147 verde lichene	43	119 laguna		
307	140 java	58	99 caffè	311	144 grigio lava	313	146 blu scuro	315	148 verde scuro	33	111 verde oliva		
		84	128 moro	46	102 nero					316	149 verde terra		

ECOLORSYSTEM SAHARA GLASS

551	nocciola sahara	552	corda sahara	517	lino sahara	512	grigio seta sahara	514	verde lichene sahara	574	canapa sahara
506	terracotta sahara	508	pepe sahara	524	grigio artico sahara	522	blu oceano sahara	515	verde scuro sahara	543	laguna sahara
507	amaranto sahara	509	sandalo sahara	521	grigio scuro sahara	513	blu scuro sahara			523	verde oliva sahara
540	java sahara	519	caffè sahara	511	grigio lava sahara						
		584	moro sahara	546	nero sahara						

ECOLORSYSTEM TAIGA GLASS

851	nocciola taiga	852	corda taiga	817	lino taiga	812	grigio seta taiga	814	verde lichene taiga	874	canapa taiga
806	terracotta taiga	808	pepe taiga	824	grigio artico taiga	822	blu oceano taiga	815	verde scuro taiga	843	laguna taiga
807	amaranto taiga	809	sandalo taiga	821	grigio scuro taiga	813	blu scuro taiga			823	verde oliva taiga
840	java taiga	819	caffè taiga	811	grigio lava taiga						
		884	moro taiga	846	nero taiga						

ECOLORSYSTEM METALIZED GLASS

GLOSSY MATT		SAHARA		TAIGA		DIAMANTE	
304	137 platino	504	platino sahara	804	platino taiga	404	platino diamante
69	126 palladio	569	palladio sahara	869	palladio taiga	469	palladio diamante
83	127 piombo	583	piombo sahara	883	piombo taiga	483	piombo diamante
301	134 peltro	501	peltro sahara	801	peltro taiga	401	peltro diamante
302	135 grafite	502	grafite sahara	802	grafite taiga	402	grafite diamante
303	136 bronzo	503	bronzo sahara	803	bronzo taiga	403	bronzo diamante
300	133 rame	500	rame sahara	800	rame taiga	400	rame diamante

NEUTRAL GLASS

55	specchio
68	specchio grigio

TRANSPARENT GLASS

890	trasparente taiga
590	trasparente sahara
490	trasparente diamante
05	trasparente extrachiaro
00	trasparente
63	grigio trasparente
65	bronzo trasparente
390	verde trasparente
391	blu trasparente

SATINATED GLASS

67	riflettente chiaro
64	riflettente grigio
81	riflettente bronzo
891	acidato taiga
591	acidato sahara
02	acidato extrachiaro
01	acidato
03	acidato grigio
04	acidato bronzo
82	nuvola extrachiaro
80	nuvola

MESH GLASS

60	rete alluminio
61	rete inox
62	rete bronzo
66	maglia gold
87	maglia rame
06	fibra argento
08	fibra bronzo

REFLEX GLASS

90	bianco reflex
92	kaki reflex
94	cacao reflex
89	nero reflex

ECOLORSYSTEM MATT LACQUERED

 305 cipria	 45 avorio	 59 grigio chiaro	 40 grigio cenere	 53 bianco neve	 16 bianco latte
 51 nocciola	 52 corda	 56 lino	 312 grigio seta	 47 grigio perla	 78 sabbia
 306 terracotta	 85 tufo	 310 creta	 38 azzurro cera	 36 blu Londra	 74 canapa
 76 rosso india	 308 pepe	 317 grigio artico	 35 blu notte	 39 verde inglese	 73 giallo kashmir
 75 amaranto	 309 sandalo	 88 grigio scuro	 86 blu oceano	 314 verde lichene	 43 laguna
 307 java	 58 caffè	 311 grigio lava	 313 blu scuro	 315 verde scuro	 33 verde oliva
	 84 moro	 13 nero			 316 verde terra





LEATHER

 C23 bianco ghiaccio
 C17 sand
 C29 toupè
 C22 caramello
 C28 fango
 C11 moka

SYNTHETIC LEATHER

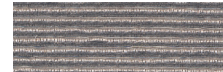
 157 arena
 158 agata
 155 nube
 154 argilla
 160 miele
 153 castoro
 159 etna
 156 rubens



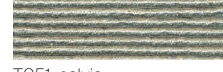





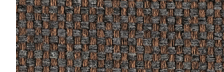

LUX FABRIC

 T006 gesso
 T052 segale
 T044 acciaio
 T012 marmotta
 T042 ruggine
 T051 salvia

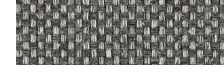
MATERIAL FABRIC

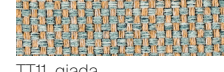
 T020 nebbia
 T019 papiro
 T009 piuma
 T017 roccia
 T001 terracotta
 T003 brandy
 T018 tabacco







TECH FABRIC

 TT01 duna
 TT03 tortora
 TT05 mosto
 TT07 antracite
 TT09 fumo
 TT10 ghiaccio
 TT11 giada
 TT19 canyon
 TT20 dolomiti
 TT21 cedro





RAFIA

 T133 magnolia
 T134 desert
 T101 natural
 T115 stone
 T102 sequoia





ECOLORSYSTEM LACQUERED METALIZED

 304 platino	 302 grafite
 69 palladio	 303 bronzo
 83 piombo	 300 rame
 301 petro	

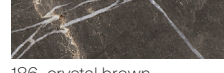

ALUMINIUM

 31 alluminio lucido
 30 alluminio
 14 brown
 318 nickel grigio
 22 nero lucido

MARBLE

 28 calacatta
 188 sierra beige
 184 crystal grey
 186 crystal brown
 180 emperador
 183 noir saint laurent
 187 verde lepanto
 182 rosso lepanto
 181 nero marquina

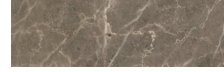
MATT MARBLE

 198 calacatta opaco
 194 crystal grey opaco
 191 nero marquina opaco
 185 crystal white opaco

LITECH

 G001 crema
 G002 moka
 G003 piedra
 G004 grigio rigato

WOOD

 711 rovere
 15 noce
 19 rovere termotrattato
 27 rovere nero
 710 tinto ebano

TAIGA WOOD

 701 rovere taiga
 700 tinto ebano taiga

SAHARA WOOD

 17 noce sahara
 20 rovere termotrattato sahara

MELAMINE

 07 melaminico olmo
 09 melaminico rovere grigio
 25 melaminico larice carbone

INTERNAL MELAMINE

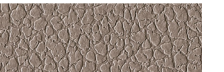
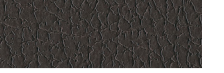
 UB07 mel. cuoio grigio
 UB09 mel. cuoio brown

Collection designed by Giuseppe Bavuso.

Art direction and graphic project: Juma
Photo: Federico Cedrone
Technical photo: F2 Fotografia
Render images: Suprema unlimited reality
Styling: Studiopepe; Patrizia Cantarella with Rossella Ballabio;
Martina Lucatelli with Martina Dalla Bona;
Simona Silenzi Studio; Gaia Marchesini and Giordano Sarno.

Thanks to: Afolki, Agape, Ames, Amini Carpets, aponteboretti, Arnolfo di Cambio, Artemide, Astep, AYTM, Azucena, B&B Italia, Baxter, Bitossi Ceramiche, Brionvega, Carl Hansen & Søn, Claire Lune, Cooe Design, Danese Milano, Dany GILLES, Davide Groppi, De Vecchi Milano 1935, Dechem Studio, Dep Art Gallery, Egidio Milesi, Emil, Etel Milano, Flexform, Flos, FontanaArte, FPM Milano, Fritz Hansen, Gan Rugs, Gardeco, Gervasoni 1882, Henry Timi, Ittala, Ivano Redaelli, Iwata Mokku, J. & L. Lobmeyr, Knoll, Lanerossi, Lindell & Co, Living Divani, Lorenzo Franceschinis, Louis Poulsen, Maru Gallery, Matteo Thun Atelier, distributed by Manus Factor, Maxalto, Nemo Lighting, Noorstad, Noorth, Nude Glass, NUMA Limited Editions, Nuove Forme, Officine Saffi, Oluce, Pallucco, Phantom Hands, Raawi, Rains, Raumgestalt, Riva 1920, Scandola marmi, Serafino Zani, Skagerak, Society, STELTON distribuito da Schönhuber Spa, Suede, Tacchini, Terry Davies Ceramics, Unurgent Argilla, Up To You Anthology, Vitra, When Objects Work.

Films and print: Optima
Update, March 2025



RIMADESIO SPA
Via Furlanelli 96
20833 Giussano (MB) Italy
T +39 0362 3171
rimadesio@rimadesio.it

MILANO FLAGSHIP STORE
Via Visconti di Modrone 26
20122 Milano Italy
T +39 02 76280708
milano@rimadesio.it

LONDON FLAGSHIP STORE
83-85, Wigmore street
1WU 1DL London
T +44 2074 862193
london@rimadesio.co.uk

NEW YORK FLAGSHIP STORE
102 Madison Ave
New York, NY 10016
T +1 917 388 2650
usa@rimadesio.us

PARIS FLAGSHIP STORE
25, Avenue Rapp
75007 Paris
T +33 1 71930682
paris@rimadesio.fr

MIAMI FLAGSHIP STORE
2601 Biscayne Blvd
Miami, FL, 33137
miami@rimadesio.us

www.rimadesio.it



Follow us on Instagram, Facebook, LinkedIn,
WeChat, Weibo, Little Red Book.

AWARDS

1993	Siparium	Young & Design
2000	Zenit	Award KBB
2001	Zenit	selection Design Index ADI
2002	Siparium	Top100 Frames
2005	Graphis	selection Design Index ADI
2007	Vela	selection Design Index ADI
2008	Vela	mention XXI Premio Compasso d'Oro ADI
2015	Wind	winner Red Dot Award
2016	Cover	Best Furniture System AZ Award
2016	Alambra	selection Design Index ADI
2017	Sail	selection Design Index ADI
2017	Soho	Architectural products AZ awards
2017	Daimon	Interior Design Magazine Best of Year awards
2020	Modulor	People's Choice winner AZ Awards
2020	Modulor	Architectural Products Award of Merit AZ Awards
2020	Modulor	selection Design Index ADI
2021	Francis	selection Design Index ADI
2021	Modulor	LivingEtc Style Awards
2022	Maxi	selection Design Index ADI
2022	Aliante	finalist Interior's best of the Year awards
2022	Aliante	finalist A+Product awards
2023	Maxi	winner German Design Awards
2023	Radius	Architect's Newspaper's Best of Products Awards
2024	Aliante	German Design Awards
2025	Air system	winner German Design Awards

PATENTED:

Air System, Altair, Air, Radius, Aliante, Rialto, Maxi, Sail, Soho, Velaria, Stripe, Daimon, Graphis, Zen, Zen frame, Siparium, Moon, Vela, Luxor, Even, Aura, Spin, Link+, Planet, Flat, Alambra, Abacus living, Self, Cover, Zenit, Dress bold, Abacus.

REGISTERED TRADEMARKS:

Rimadesio, Ecolorsystem, Litech, Siparium, Velaria, Abacus.